

SkyWave

IDP 600 Terminal Series

Hardware Guide

T200, Version 05



The electronic version of this document allows you to use the built-in Hyperlinks and bookmarks when using Adobe Reader

Legal Notice

This documentation is owned by SkyWave Mobile Communications Inc. (SkyWave) and protected by applicable copyright laws and international treaty provisions. Other copyrighted names used are the property of their respective owners. Therefore, you must treat this documentation like any other copyrighted material. You may not make the documentation, or copies thereof, available in any manner or form, or use, copy or transfer any part, to anyone outside your company.

If you received this documentation by electronic transmission or download, by installation or use of the documentation, you acknowledge that you have read and understand this license agreement and agree to be bound by its terms and conditions.

This documentation is provided on an as-is basis without any warranty of any kind. You assume the entire risk as to the results or performance of the software. Under no circumstance shall SkyWave be held liable for any direct, indirect, consequential, or incidental damages arising from the use or inability to use the software or documentation.

All trademarks or registered trademarks are the property of their respective owners. INMARSAT, the Inmarsat logo and IsatData Pro are trademarks of Inmarsat used under license by SkyWave. Inmarsat is not responsible for the operation and regulatory compliance of the products and services referred to in this document that connect to the Inmarsat system.

SkyWave reserves the right to make changes to products and or specifications without notice.

Contact Information

SkyWave Mobile Communications Inc.

Online:

- Website www.SkyWave.com

Online Documentation:

- Login at support.skywave.com and follow the link to the downloads section

Customer Support by Email:

- support@skywave.com

Customer Support by Telephone:

- +1.613.836.2222

TABLE OF CONTENTS

Legal Notice..... ii

Contact Information..... ii

List of Figures vi

List of Tables..... vii

Preface ix

 What's New? ix

 Purpose ix

 Audience ix

 Notation ix

 Reference ix

 Important Information about the IDP-680 CID2 and IDP-690 CID2 Terminals..... x

 Safety Disclaimer..... x

 Safety Precautions..... x

 Installation Warning x

 Limited Liability xi

 Warranty xi

 User Serviceable Parts xi

1 Product Overview 1

 1.1 Overview of the Messaging System 1

 1.2 Terminals..... 2

 1.3 Terminal Key Features and Benefits 5

 1.4 Pass-Through Mode 5

 1.5 Operating Modes 6

2 Compliance 9

3 Specifications 11

 3.1 Hardware Versions 11

 3.2 Connector 11

 3.2.1 Connector Pin-out..... 12

 3.3 Power..... 13

 3.3.1 Input Range..... 13

 3.3.2 Power Consumption..... 13

 3.3.2.1 Average Power Consumption..... 14

 3.3.3 Load Dump Circuitry..... 15

 3.3.4 Fuse..... 15

 3.4 Input/Output 15

 3.4.1 Digital Input..... 16

 3.4.2 Digital Output 17

 3.4.3 Analog Input 18

 3.4.4 Input Bandwidth 18

 3.4.5 Output Bandwidth..... 19

 3.4.6 Pass-Through Mode..... 19

 3.5 Serial Interfaces..... 20

 3.5.1 RS-232 20

3.5.2	RS-485	20
3.6	RF Specifications	21
3.6.1	Frequency	21
3.6.2	IDP-680 Antenna	21
3.6.3	IDP-690 Low Elevation Antenna	21
3.7	GPS.....	21
3.8	Physical Details	22
3.9	LED	25
3.10	Non-Volatile Storage.....	25
3.11	Environmental	26
3.12	Temperature Sensor.....	27
4	Installation	29
4.1	Getting Started.....	29
4.2	Prepare for the Installation	29
4.2.1	Shipping Box Contents	30
4.2.2	Mobile Identification	30
4.2.3	Contact SkyWave to Activate the Terminal	30
4.2.4	Required Tools and Materials.....	31
4.3	Identify the Fuse Panel Location.....	32
4.4	Determine a Suitable Mounting Location	32
4.5	Route the Main Cable.....	33
4.6	Mount the Terminal.....	35
4.6.1	Drill Mounting Holes (optional).....	35
4.6.2	Mount the Terminal	36
4.6.3	Apply Dielectric Grease.....	36
4.7	Protect the Cables and Cable Connectors.....	38
4.8	Connect to Power	39
4.9	Register the Terminal	40
4.10	Cleaning Instructions.....	41
4.11	Application Programming Interface	41
5	Cable Assembly Instructions.....	43
5.1	Required Tools and Materials	43
5.2	Cable Assembly Steps.....	43
6	Troubleshooting the Terminal	49
6.1	Terminal Does Not Register or Report.....	49
APPENDIX A	Order Part Numbers.....	51
APPENDIX B	Activation Information	52
APPENDIX C	IDP 600 Series Blunt Cut Cable.....	53
APPENDIX D	IDP 600 Series to DMR-800 Adaptor Cable.....	55
APPENDIX E	IDP 600 Series Extension Cable.....	57
APPENDIX F	Installation Instructions for a Pole Mount Kit	59
APPENDIX G	Installation Instructions for the IDP-680 CID2 and IDP-690 CID2.....	64
APPENDIX H	Drill Template	66
	Documentation Version.....	67

Acronyms/Glossary 68
Index... 69

List of Figures

Figure 1	IDP-680 Model.....	1
Figure 2	SkyWave's IsatData Pro Network	2
Figure 3	IDP-680 with Side Connector.....	3
Figure 4	IDP-680 with Bottom Connector.....	3
Figure 5	IDP-690 with Side Connector.....	4
Figure 6	IDP-690 with Bottom Connector.....	4
Figure 7	IDP-680 CID2 with Conduit Adaptor	4
Figure 8	IDP-690 CID2 with Conduit Adaptor	5
Figure 9	Pass-Through Mode.....	6
Figure 10	Terminal Connector Pin Assignment (Male).....	12
Figure 11	View of Terminal Male Connector.....	12
Figure 12	Face View of Mating Connector (Female)	13
Figure 13	Rear View of Mating Connector (Solder Cups)	13
Figure 14	Digital Input.....	16
Figure 15	Digital Output.....	17
Figure 16	Analog Input.....	18
Figure 17	Pass-Through Mode Signals.....	19
Figure 18	IDP-680 Top View Enclosure Dimensions (mm)	22
Figure 19	IDP-680 Side View Enclosure Dimensions (mm).....	23
Figure 20	IDP-680 and IDP-690 Top View Enclosure Dimensions (mm).....	23
Figure 21	IDP-690 Side View Enclosure Dimensions (mm).....	23
Figure 22	IDP 600 CID2 Series Bottom View Enclosure Dimensions (mm).....	24
Figure 23	IDP-680 CID2 Side View Enclosure Dimensions (mm).....	24
Figure 24	IDP-690 CID2 Side View Enclosure Dimensions (mm).....	24
Figure 25	Mobile ID Location	30
Figure 26	Sample Activation Report	31
Figure 27	Sample Cable Placement in a Vehicle Cab	34
Figure 28	Bottom Connector and Side Connector (IDP-680 shown)	35
Figure 29	Location for Waterproof Sealing Compound	36
Figure 30	Apply Silicone Lubricant to Connector.....	37
Figure 31	Key Slot.....	37
Figure 32	Cable Connector and Locking Collar	38
Figure 33	Cable Management.....	39
Figure 34	LED Location	40
Figure 35	Basic Connector Parts for Soldering Configuration	43
Figure 36	Recommended Stripping Length	44
Figure 37	Cable with Sealing Nut, Back Shell and Coupling Ring.....	44
Figure 38	Cable Grommet	44
Figure 39	Red Gasket.....	45
Figure 40	Wires and Solder Cups	45
Figure 41	O-Ring over Connector Body.....	45
Figure 42	Silicone in the Connector	46
Figure 43	Silicone in the Grommet.....	46

Figure 44	Key Features in the Coupling Ring and Connector Body	46
Figure 45	Cable Exit Area	46
Figure 46	Assembled Sealing Nut	47
Figure 47	IDP 600 Series Blunt Cut Cable	53
Figure 48	Face View of IDP 600 Series Blunt Cut Cable Connector	54
Figure 49	Raw Cable Details	54
Figure 50	IDP 600 Series to DMR-800 Adaptor Cable	55
Figure 51	IDP Connector End Pin-Out	56
Figure 52	DMR-800 Mating Connector End Pin-Out	56
Figure 53	IDP 600 Series Extension Cable.....	57
Figure 54	Raw Cable Details	58
Figure 55	Silicone Lubricant and Connector	60
Figure 56	Bracket and Screws	60
Figure 57	Bracket Orientations.....	61
Figure 58	Feed the Clamps through the Slots	61
Figure 59	Tighten the Clamps.....	61
Figure 60	Cable Exit.....	62
Figure 61	Secure the Cable	62
Figure 62	Tie the Cable.....	63
Figure 63	Installation Assembly Diagram	64
Figure 64	Example Conduit Fitting	65
Figure 65	Apply Silicone Lubricant to the Connector	65

List of Tables

Table 1	IDP 600 Series Models	3
Table 2	Hardware Comparison.....	11
Table 3	Terminal Connector.....	11
Table 4	Terminal Electrical Pin Assignment (IDP-680 and IDP-690).....	12
Table 5	Power Consumption Values (all terminals).....	13
Table 6	Power Consumption Scenarios	14
Table 7	Pass-Through Mode I/O States.....	19
Table 8	Pass-Through Mode Timing Specifications	19
Table 9	Pass-Through Mode Power Consumption.....	20
Table 10	Order Part Numbers.....	51
Table 11	IDP 600 Series Mating Blunt-Cut Cable Color Code.....	54
Table 12	Cable Connector Pin-Out	56
Table 13	Cable Connector Pin-Out	58

THIS PAGE INTENTIONALLY LEFT BLANK

Preface

Note: Refer to the SkyWave Customer Support website for a possible Errata Sheet available after the release of this document. Always check the site for the most current documentation releases.

What's New?

Updates since the last release of this document are listed below.

- Introduction of the IDP-680 CID2 and IDP-690 CID2 terminals
- General updates throughout the document

Purpose

This document is as an overview of the installation procedures and hardware characteristics and specifications for the IDP 600 series of terminals.

Audience

This document is for technical readers. It provides information to ensure successful installation and operation of IDP 600 series terminals.

Notation

Hardware components and hardware labels in this document may not be exactly as shown and are subject to change without notice.

CAUTION *This safety symbol warns users of possible hazards to personnel, to equipment, or to both. It includes hazards that will or can cause severe personal injury, death, or substantial property damage if the hazard is not avoided; and hazards that will or can cause minor personal injury or property damage if the hazard is not avoided.*



Note: A note indicates information with no potential hazard, but the user should make special note. A note is also used to indicate points of interest or to provide supplementary information about a feature or task.

Numbered lists indicate a series of steps required to complete a task or function.

Bulleted lists highlight information where order or sequence is not crucial.

Reference

The content of the following documents may be useful in conjunction with this guide. These documents are available from the IDP Developer Toolkit or support.skywave.com.

[T202] IDP 600 Terminal Series Developer Guide

Important Information about the IDP-680 CID2 and IDP-690 CID2 Terminals

WARNING  *This equipment is suitable for use in Class I Division 2 (CID2), Groups A, B, C and D locations or non-hazardous locations only.*

WARNING  *Explosion hazard – Do not connect or disconnect equipment unless power has been switched off or the area is known to be non-hazardous.*

AVERTISSEMENT – Risque d’explosion – Avant de connecter ou de déconnecter l’équipement, couper le courant ou s’assurer que l’emplacement est désigné non dangereux.

WARNING  *Explosion hazard – Substitution of components may impair suitability for Class I, Division 2.*

AVERTISSEMENT – Risque d’explosion – La substitution de composants peut rendre ce matériel inacceptable pour les emplacements de Class I, Division 2.

Safety Disclaimer

SkyWave makes no warranties, representations or guarantees that the products and network services are suitable for any use in any hazardous environments requiring fail safe performance (including without limitation marine safety and distress systems, operation of nuclear facilities, aircraft navigation or communications systems, weapons systems, air traffic control and life support services) or any other application in which the failure of the products or network services could result in death or personal injury. Solution Providers assume all liability associated with selling any products and network services for any such applications, and Solution Provider will defend, indemnify, and hold SkyWave harmless against any claims against SkyWave for loss, damage, liability, or expense (including lawyers’ fees) arising out of or related to the sale by Solution Providers or any Solution Provider Reseller, or the user by any end user, of any product or network service.

Please read all cautions and warnings throughout this document.

Safety Precautions

The mobile device must comply with all safety precautions relating to the operation, usage, service and repair of the terminal. SkyWave assumes no liability for the customer’s failure to comply with any of these precautions.

Caution warnings appear throughout this document.

Installation Warning

SkyWave recommends that this product be installed by the authorized distributor from whom it has been purchased. By carrying out the installation of the product, the installer

assumes exclusive responsibility for, and agrees to indemnify SkyWave from, any injury or damage of any kind arising from the installation.

Limited Liability

SkyWave's liability is limited to the cost of repair or replacement of any of SkyWave's products during the warranty period. To the maximum extent permitted by applicable law, SkyWave's total liability for damages of any kind, whether based on breach of contract, tort (including negligence), product liability, incidental, special, consequential, indirect or similar damages with product application and usages will be limited to an amount equal to the product's original price paid by the Purchaser to SkyWave and this limitation of liability is reasonable given the price of SkyWave's products. In no event will SkyWave be liable to the Purchaser, any resellers of the Purchaser or any end user for any lost profits or savings, lost business, loss of data, any telecommunications breakdown, unavailability, downtime, interruption or delay, any suspension of service by any third party service provider including Inmarsat or any incidental, special, indirect, or consequential damages, whether based on breach of contract, tort (including negligence), product liability, incidental, special, consequential, indirect or similar damages and whether or not SkyWave has been advised of the possibility of such occurrence or damage. The parties agree that the foregoing represents a fair allocation of risk hereunder.

Warranty

SkyWave provides a manufacturer's warranty to the original purchaser (Solution Provider) that its products and services will perform in accordance with SkyWave's specifications and will be free from defects in material and workmanship for a limited period of time. This warranty is limited to the repair and/or replacement of any defective components experienced under normal specified operating use and storage conditions, at SkyWave's discretion. It does not cover any damages caused or associated with the product's misuse. The end-user's only remedy or recourse is against the Solution Provider, and any experience with defective products should be communicated to your Solution Provider. Shipping of defective product, back to the Solution Provider will be in accordance with the Solution Provider's instructions and should be accompanied with a fault report. SkyWave is not responsible for corrosion damage caused by improperly assembled or installed cables. **Warranty is void if unit is opened.**

A fault report is required for each unit returned under warranty. Please contact SkyWave's Customer Support for additional information.

User Serviceable Parts

The terminals contain no user serviceable parts or replaceable fuses.

THIS PAGE INTENTIONALLY LEFT BLANK

1 Product Overview

Each IDP 600 series terminal consists of a single environmentally sealed mechanical enclosure containing an integral antenna, a satellite modem for communicating with the satellite, an integral GPS subsystem, four input/output ports, an RS-232 port, and an RS-485 port. The terminals are available in various configurations. Figure 1 shows the IDP-680 model.

Figure 1 IDP-680 Model



Each terminal is designed for industrial and fixed applications or to be mounted outdoors on a wide range of platforms such as vehicles or boats.

The terminal's built-in programmability allows it to work as a stand-alone data-messaging terminal, with built-in I/O data collection and processing capabilities. Feature-rich software tools make programming easy and shorten the design and testing time.

1.1 Overview of the Messaging System

SkyWave's IsatData Pro satellite messaging system is designed to support the management of mobile or fixed assets located around the world. An asset fitted with one of SkyWave's satellite based mobile terminals can have its status and location monitored, as well as send large messages.

The network provides the following key features and benefits:

- Polling of terminal status and location
- Scheduled reporting of terminal status and location
- Transmission of text messages to and from a serial port on the terminal
- Two-way communication for messaging to and from the asset for near real-time control
- Up to 6,400 bytes from-mobile messages
- Up to 10,000 bytes to-mobile messages
- Broadcast messages

- Default acknowledged messages
- Global service

Figure 2 SkyWave's IsatData Pro Network

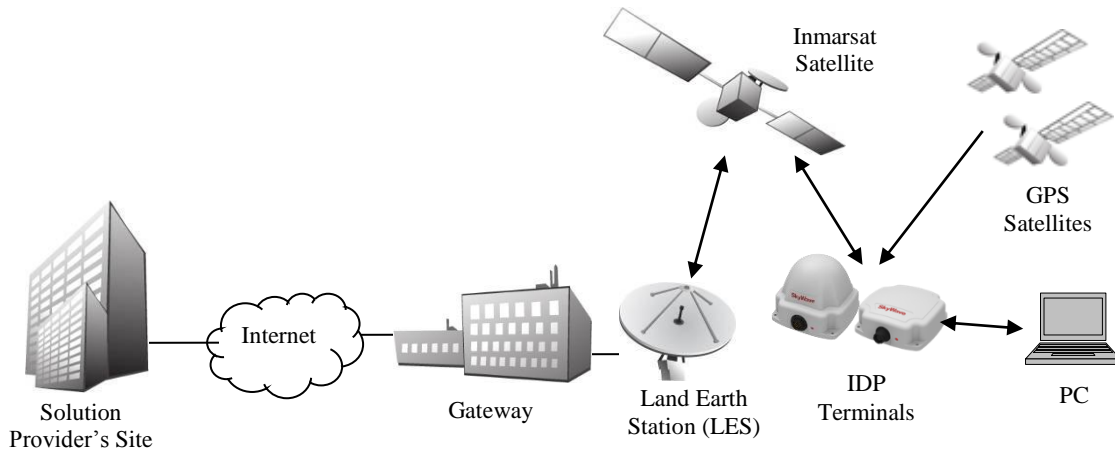

Service is provided to end users by Solution Providers (SPs) who use the SkyWave IsatData Pro network to offer particular applications and/or services to their clients. The SPs link their application services to the satellite terminals by connecting to the IsatData Pro gateway. This acts as the communications hub of the system, routing traffic to and from the terminals and the various service providers.

Configuration and data retrieval from the terminal can be easily accomplished through Internet-based application services provided by SPs or by integrating existing customer enterprise software to receive information from the Gateway.

1.2 Terminals¹

The IDP 600 series (Table 1) of SkyWave mobile satellite terminals operate on the IsatData Pro network. The terminals are self-contained, environmentally sealed, compact, and provide low power consumption.

Terminals include an omni-directional antenna, satellite modem, GPS, programmable microcontroller, and several I/O (input/output) feeds capable of monitoring and controlling external sensors and devices.

The terminal's built-in programmability allows it to work as a stand-alone terminal with built-in I/O data collection and processing capabilities. Each model is suitable for both mobile and fixed installations.

Feature-rich software tools make scripting easy, and shorten the script design and testing time. SkyWave also provides consulting services to SPs to help program the terminals and get customer applications running quickly.

¹ Hardware components may not be exactly as shown in this document.

Table 1 IDP 600 Series Models

Model	Elevation Angle	Connector
IDP-680	20° - 90°	10-pin side or bottom
IDP-690	-15° - 90°	10-pin side or bottom

Part numbers are specified in Table 10.

Terminals are available in two configurations: bottom connector or side connector (see figures below). The terminals are also available with a bottom connector CID2 option (Figure 7).

Figure 3 IDP-680 with Side Connector



Figure 4 IDP-680 with Bottom Connector



Figure 5 IDP-690 with Side Connector



Figure 6 IDP-690 with Bottom Connector



Figure 7 IDP-680 CID2 with Conduit Adaptor



Figure 8 IDP-690 CID2 with Conduit Adaptor

1.3 Terminal Key Features and Benefits

CAUTION *Do not rely solely on the terminal for emergency (SOS) calls.*



The IDP 600 series terminals have the following key features and benefits:

- Designed to be used as a standalone or incorporated into an SP solution
- Built-in GPS receiver to calculate position, speed and heading
- Quick and easy installation reduces labor time and costs
- Ships with installed firmware
- Flexible custom scripting
- Broad operational temperature range
- Rugged construction

1.4 Pass-Through Mode

The terminal operates in pass-through mode when there is no valid application firmware present. In pass-through mode, the terminal connects the external RS-232 port to the serial port on its internal modem, making the terminal an IP67 modem that accepts a wide input voltage. The packaged modem inherits all the IDP 600 terminal series certifications.

Figure 9 Pass-Through Mode

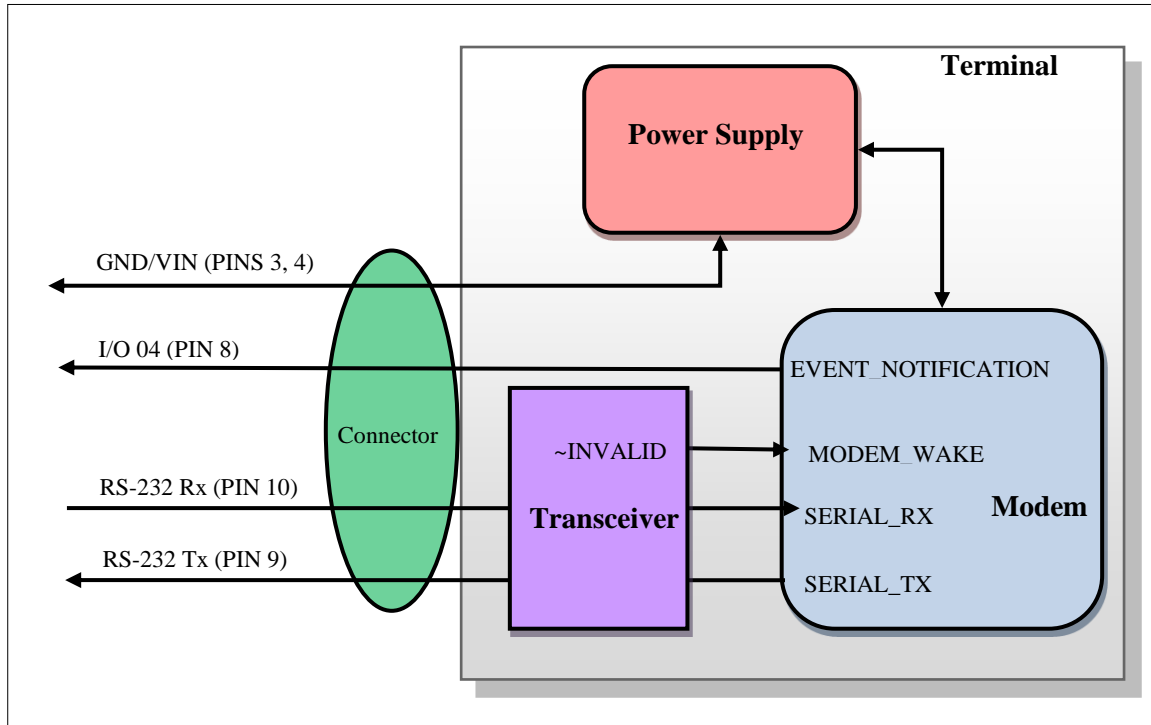

1.5 Operating Modes

The terminal operates in a number of modes while the application processor portion of the terminal has its own independent set of modes.

Transmit Mode

In transmit mode the terminal is transmitting a signal to the gateway. Several transmissions can occur within any 5 second frame.

Satellite Communications Receive Mode

In satellite communications receive mode the modem is attempting or actively receiving an over-the-air signal from the gateway either via the bulletin board channel or the traffic channel. When the modem is tracking the traffic channel and is not in low power mode, the satellite communications receiver is on for approximately 0.5 seconds every 5 seconds to receive and decode the traffic channel sub frames. This is mutually exclusive with transmit mode. The network ensures that transmit and receive signals do not collide and ensures full duplex operation.

GPS Mode

In GPS mode the GPS receiver is on and the modem is attempting to or actively receiving the GPS signal in order to acquire a GPS fix.

Sleep Mode

In sleep mode the terminal draws minimal current. It monitors its external inputs (digital and serial) for activity, and reacts as required by transitioning to processing mode with no loss of information such as incoming serial characters.

Processing Mode

In its processing mode the applications processor is actively running while transmit and receive are powered down.

THIS PAGE INTENTIONALLY LEFT BLANK

2 Compliance

The IDP terminals obtained the following certifications:

Inmarsat Type Approval

Industry Canada

- IC:3745A-IDP6XX
- RSS-170, Issue 2, Spectrum Management and Telecommunications Policy, Radio Standard

FCC Part 25

- FCC ID: B92IDP6XX
- CFR Title 47: Telecommunication, Part 25 - Satellite Communications, Sub-part C - Technical Standards
- OET 65 - Radiation Safety

R&TTE Directive 1999/5/EC (CE Mark)

Safety (art3.1.a)	EN 60950-1:2006 + A11:2009 EN 62311:2008
EMC (art3.1.b)	EN 301 489-1 V1.9.2 (2008-04) EN 301 489-20 V1.2.1 (2002-11)
Spectrum (art 3.2)	EN 301 426 V1.2.1 (2001-10)

IEC 60945 (non CID2 IDP-690 only)

Compliant with the following sections of IEC 60945 (2002) - Maritime navigation and radio communication equipment and systems:

The normal input voltage for IEC 60945 compliance is declared as 12/24 V. With this nominal input voltage, the IDP-690 meets IEC 60945 requirements for power supply operation of -25%/+30% (9 to 32 V).

Equipment Performance	N/A
Dry Heat	IEC60945 Section 8.2.2.2, IEC60068-2-2
Low Temperature	IEC60945 Section 8.4.2.3, IEC60068-2-1
Humidity	IEC60945 Section 8.3, IEC60068-2-30
Vibration	IEC60945 Section 8.7.2, IEC60068-2-6
Insulation Resistance	IEC60945 Section 8.3 and 8.4, IEC60092-504
Power Supply Variation	IEC945 Section 10.7.1 and 10.7.2, IEC60092-504
Power Supply Failure	IEC945 Section 10.8.2, IEC60092-504
Acoustic Noise	IEC60945 11.1.2
Compass Safe Distance	IEC60945 11.2.2 Compass Safe Distance 20 cm
Salt Mist	IEC945 Section 8.12, IEC 60069-2-52 Severity 1

Radiated Emissions	EN 55016-2-3:2006
Radiated Immunity	IEC61000-4-3:2006 + A1:2008
Conducted Emissions	EN 55016-2-1:2009
Conducted Immunity	IEC61000-4-6:2009
Fast Burst Transients	IEC61000-4-4:2004
Electrostatic Discharge	IEC61000-4-2:2009
Surge (Applicable to AC powered equipment)	IEC61000-4-5

RoHS

Restriction of Hazardous Substances (RoHS)²

Ingress Protection

IP67

Anatel

Technical Compliant. Anatel homologation must be held by a Brazilian company.

Class I Division 2 (Groups A, B, C and D)

The IDP CID2 terminals are listed to the following:

- ANSI/ISA-12.12.01-2011 - Nonincendive Electrical Equipment for Use in Class I and II, Division 2 and Class III, Divisions 1 and 2 Hazardous (Classified) Locations

² European Union's (EU) Directive 2002/95/EEC "Restriction of Hazardous Substances" (RoHS) in Electronic and Electrical Equipment.

3 Specifications

3.1 Hardware Versions

The IDP 100 series terminals are available in different hardware configurations as per Table 2. Part numbers are found in APPENDIX A.

Table 2 Hardware Comparison

Terminal Hardware Revision Number ³	Modem Hardware Number ⁴	Features
3	3	Standard GPS, 1M terminal application SRAM
5	4	Hardware GPS, jamming detect, Doppler correction, 2M terminal application SRAM

3.2 Connector

The terminals use a circular 10-pin connector.

Table 3 Terminal Connector

Parameter	Part Number
Mating Connector Kit	SA901020-001

³ Use terminalinfo SIN 16, MIN 1 to query the number of the current terminal hardware revision number.

⁴ The modem hardware number is sometimes displayed as a major (e.g., 4) and minor (e.g., 0) number. Use terminalinfo SIN 16, MIN 1 to query the number of the current hardware.

3.2.1 Connector Pin-out

Figure 10 Terminal Connector Pin Assignment (Male)

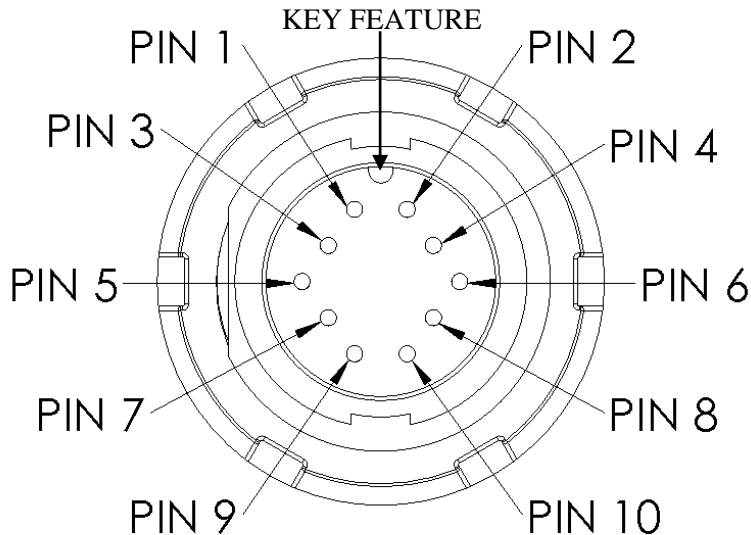

Table 4 Terminal Electrical Pin Assignment (IDP-680 and IDP-690)

Pin	Functionality	Pin	Functionality
1	RS-485A	2	RS-485 B
3	GND	4	VIN
5	I/O 02	6	I/O 03
7	I/O 01	8	I/O 04
9	RS-232 Tx (Output)	10	RS-232 Rx (Input)

Figure 11 View of Terminal Male Connector



Figure 12 Face View of Mating Connector (Female)

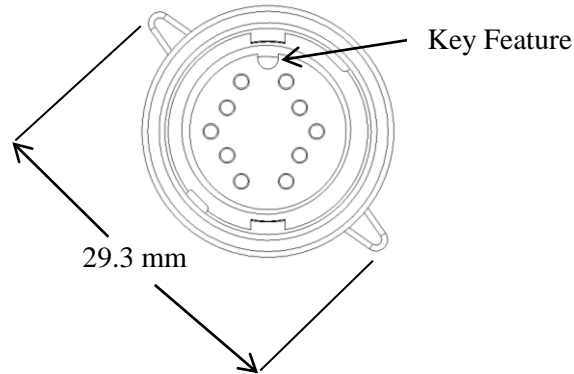
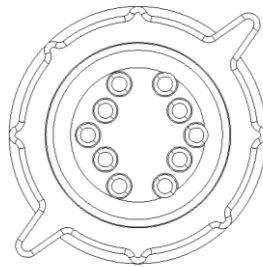

Figure 13 Rear View of Mating Connector (Solder Cups)



3.3 Power

3.3.1 Input Range

Parameter	Value
Power Supply Voltage	9 to 32 V DC
Reverse Polarity Protection	-40 V maximum

3.3.2 Power Consumption

Typical power consumption values at V_{batt}=12 V and at room temperature (22°C)

Table 5 Power Consumption Values (all terminals)

Mode of Operation	Current
Transmit	0.75 A
Satellite communications receive	45 mA
GPS	40 mA
Processing	10 mA
Sleep	100 μA
LED on	50 mA

3.3.2.1 Average Power Consumption

Terminals which are not in low power mode (i.e., which are receiving every 5s) consume a baseline of 8.3 mA on average, at 12 V (200 mAh/day). Frequent messaging, frequent GPS fixes or high usage of the LED increases power consumption.

For terminals in low power mode average terminal power consumption depends on many factors including how often the modem wakes to receive to-mobile messages, how often GPS fixes are requested, the size and frequency of mobile messages as well as the duty cycle of the LED. Table 6 characterizes several scenarios and shows the estimated average power consumption assuming a 12 V power source.

Table 6 Power Consumption Scenarios

Scenario	Baseline 5s Receive Mode	Fixed 1	Fixed 2	Mobile 1	Mobile 2
Wake to Receive Period	5 s	30 min	3 min	60 min	30 min
Tx/Day and Message Size/Tx	1X, 98 bytes	48X, 98 bytes	96X, 98 bytes	1X, 98 bytes	2X, 98 bytes
GPS Fix/Day	4 (network)	1 (network)	1 (network)	24	4 (network)
Power Mode	Mobile - powered	Fixed - battery	Fixed - battery	Mobile - powered	Mobile - battery
Average Power Consumption (mAh/day at 12 V)	200	24	111	16	11
Average Power Consumption (mA at 12 V)	8.3	1.0	4.6	4.0	0.46
Serial	None	On Rx Wake Up	On Rx Wake Up	On Rx Wake Up	None
Life of 10 A-hour battery (months)	1.8	14	3.0	20	30
Notes	-	-	-	10 seconds of application card geofence processing per fix (assumed) (terminal only)	-

3.3.3 Load Dump Circuitry

The terminal's operating range is 9-32 V. Above this range the load dump protection circuitry opens an electronic switch so that the terminal is not damaged, up to 150V. When the voltage drops below the threshold, the terminal recovers, going through power on reset.

With this protection, the terminal is capable of withstanding load dumps as specified in SAE J1455 (rev JUN2006) paragraph 4.13.2.2.1.

3.3.4 Fuse

The IDP 600 series terminals have an internal 5 A fuse. The internal fuse provides protection in the event of an internal short on the terminal. The internal fuse cannot be reset and is not field repairable.

3.4 Input/Output

The terminal's four configurable I/O lines are each independently operable in one of following modes:

- Digital Input
- Digital Output
- Analog Input
- Disabled

When disabled the I/O is physically configured as an analog input.

3.4.1 Digital Input

Figure 14 shows a schematic of the I/O when configured as a digital input.

Figure 14 Digital Input

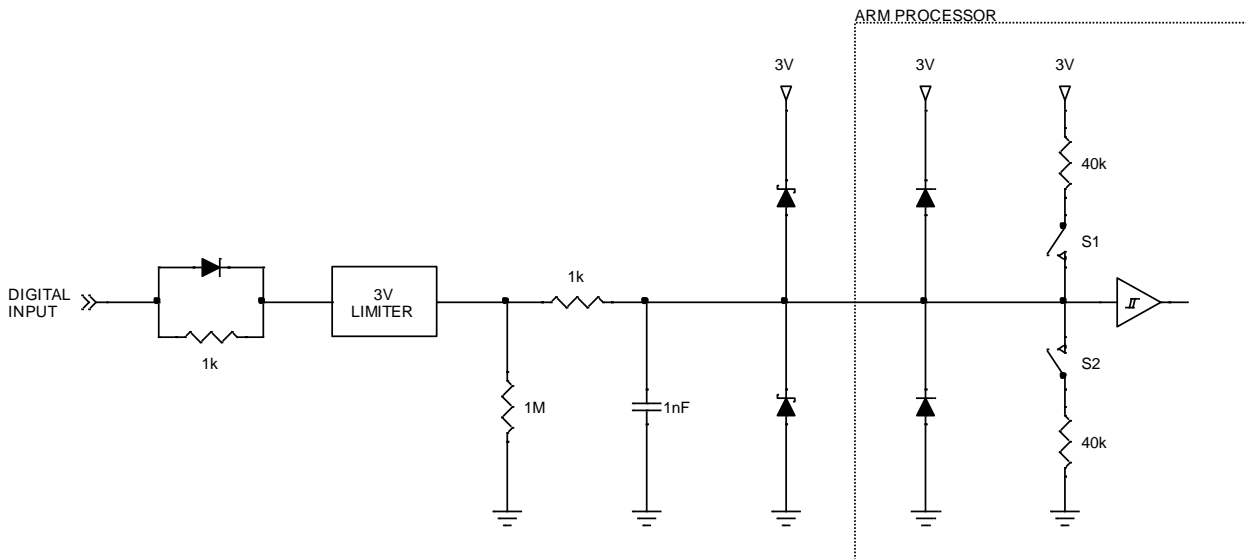

Input Type	S1	S2
With weak pull-down	Open	Open
With pull-down	Open	Closed
With pull-up	Closed	Open

The input specifications are provided in the table below.

Parameter	Minimum	Typical	Maximum	Units
Input low range	-10	-	1.05	V
Input high range	1.95	-	150	V
Input current with weak pull-down (weak 1 MΩ pull-down still in place); V _{in} = 3.0 V	-	3	-	μA
Input source current with pull-up (V _{in} = 0.0 V)	-	75	-	μA
Input sink current with pull-down (V _{in} = 3 to 150 V)	-	80	-	μA
Input Frequency	-	-	1 ⁵	Hz

⁵ This value is dependent on the Lua services being used. This is not a hardware limitation.

3.4.2 Digital Output

Figure 15 shows a schematic of the I/O when configured as a digital output. It must be noted that I/O 04 is the only I/O with built-in short circuit protection for open drain outputs.

Figure 15 Digital Output

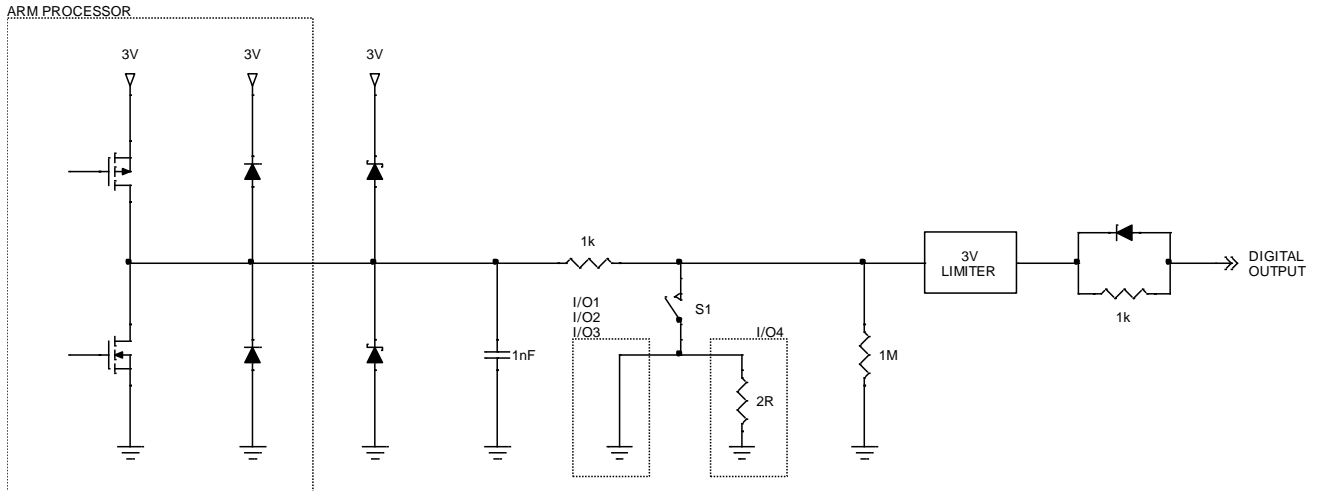

Push-pull	S1 = Open
Open drain	S1 = Closed (Low Impedance) S1 = Open (High Impedance)

The following tables describe the output specifications.

Push-pull

In the push-pull configuration the output is driven directly from the microprocessor.

Parameter	Minimum	Typical	Maximum	Units
Output high voltage - open circuit	2.85	3.0	3.15	V
Output high voltage (sourcing 25 μ A)	2.80	-	-	V
Output low voltage (sinking 25 μ A)	-	-	0.05	V

Open Drain (I/O 01 to I/O 03)

Parameter	Minimum	Typical	Maximum	Units
Sink current (do not exceed)	-	-	250	mA
Voltage (active drawing at 250 mA)	-	-	2.56	V
Absolute Limits	-10	-	150	V

Protected Open Drain (I/O 04 only)

Parameter	Minimum	Typical	Maximum	Units
Sink current (current limited)	-	-	300	mA
Voltage at 250 mA	-	-	3.09	V
Absolute Limits	-10	-	150	V

3.4.3 Analog Input

Figure 16 contains a schematic of the I/O when configured as an analog input.

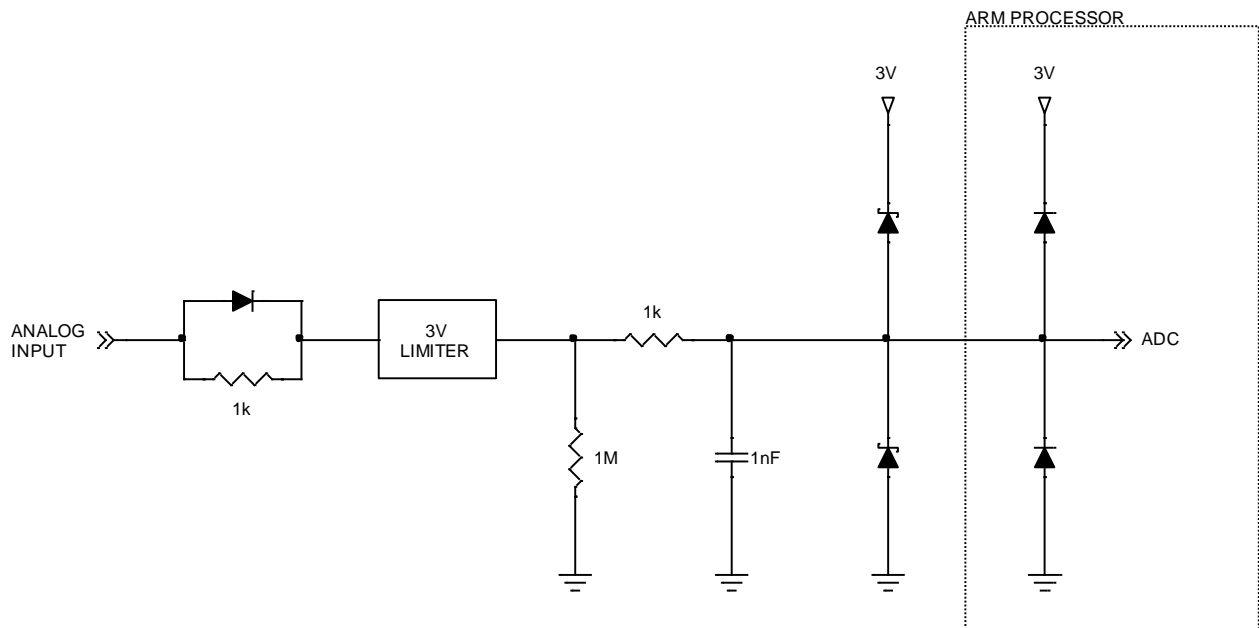
Figure 16 Analog Input

Parameter	Value
Absolute Minimum	-10 V
Absolute Maximum	150 V
Input Impedance	1 M Ω (typical)
Input Measurement Range	0 to 3 V
Resolution	0.7 mV (12 bits)
Accuracy	3% + 2 LSB

3.4.4 Input Bandwidth

When used as a digital or analog input, the I/O circuitry's bandwidth is ≥ 1 kHz.

Note: This does not imply that the terminal software has a sample rate > 1 Hz.

3.4.5 Output Bandwidth

When used as a digital output (either a push-pull or open drain) the I/O circuitry's bandwidth exceeds 100 Hz.

Note: This does not imply that the terminal software has the capability of generating high rate pulse trains at frequencies > 10 Hz.

3.4.6 Pass-Through Mode

A terminal can be configured for pass-through mode when there is no application firmware present. A block diagram of pass-through mode is shown in Figure 17. In pass-through mode, the terminal connects the modem's serial interface to the terminal's RS-232 port.

Figure 17 Pass-Through Mode Signals

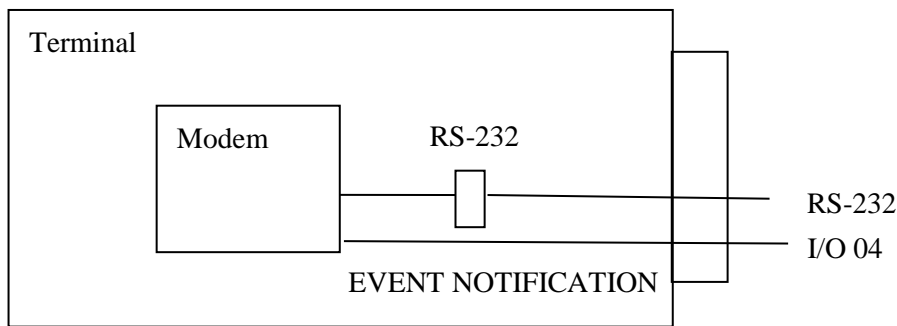

The terminal's I/O lines are configured as per Table 7 when in pass-through mode. The modem's serial data and the EVENT_NOTIFICATION pins are connected to the terminal's external connector.

Table 7 Pass-Through Mode I/O States

I/O Pin	State	Specification
I/O 04	Output	Connected to EVENT_NOTIFICATION
I/O 01, I/O 02, I/O 03	Analog Input	Do not use
RS-485	Disabled	-
RS-232	RS-232	Disabled if no valid RS-232 level on receiver

When in pass-through mode, the application controller samples inputs and drives the equivalent output appropriately. Pass-through mode time specifications are given in Table 8.

Table 8 Pass-Through Mode Timing Specifications

Parameter	Specification
Baud Rate	As per modem configuration
Maximum Jitter on Signals (Modem to External)	10 μs
Maximum Jitter on Signals (External to Modem)	10 μs

Table 9 Pass-Through Mode Power Consumption

Mode of Operation	Current ⁶
Pass-Through Mode	45 mA

3.5 Serial Interfaces

3.5.1 RS-232

The RS-232 interface defaults to the following settings: 9600 bit/s, 1 start, 8 data, 1 stop bit, no parity. The baud rate is configurable up to 230,400 bit/s.

The electrical characteristics of the interface are:

Parameter	Minimum	Typical	Maximum	Units
Serial Rx Input Low Threshold	-2.7	-	-	V
Serial Rx Input High Threshold	-	-	2.7	V
Serial Tx Low Output (3 K load)	-	-	-3.7	V
Serial Tx High Output (3 K load)	3.7	-	-	V

3.5.2 RS-485

The electrical characteristics of the interface are:

Parameter	Minimum	Typical	Maximum	Units
Input Common Mode Voltage	-7.0	-	+12	V
Differential Input Threshold	-200	-125	-50	mV
Output Common Mode Voltage	-	1.5	3.0	V
Differential Drive Output, 54 Ω load	1.5	-	-	V

⁶ Drawn from a 12 V supply. Average time of receive and idle current, with the modem receiving IsatData Pro but not transmitting or receiving GPS.

3.6 RF Specifications

3.6.1 Frequency

Parameter	Value
Receive	
Frequency Band	1525 to 1559 MHz
Modulation	OQPSK
Symbol Rate	3000 symbols/seconds
Polarization	RHCP
Transmit	
Frequency Band	1626.5 to 1660.5 MHz
Modulation	OQPSK
Symbol Rate	900 symbols/seconds (maximum)
Polarization	RHCP

3.6.2 IDP-680 Antenna

Parameter	Value
Maximum EIRP	7 dBW
Elevation Angle	20 degrees elevation
Maximum transmit antenna gain	4.5 dBic

3.6.3 IDP-690 Low Elevation Antenna

Parameter	Value
Maximum EIRP	5 dBW
Elevation Angle	-15 degrees elevation
Maximum transmit antenna gain	2.5 dBic

3.7 GPS

Standard GPS

The standard GPS is software GPS implementation on the IDP modem. It is available in terminal hardware # 3.

Parameter	Value
Frequency	L1 (1575.42 MHz)
Channels	8
Mean Time to First Fix	
Cold Start	36 s
Warm Start	8 s
Sensitivity	
Tracking	-146 dBm
Acquisition	-136 dBm

Parameter	Value
Accuracy	
Horizontal Position (CEP)	4 m
Horizontal Speed (CEP)	0.02 m/s

Hardware GPS

The hardware GPS is a third party GPS implementation. It is available in terminal hardware # 4.

Parameter	Value
Frequency	L1 (1575.42 MHz)
Channels	50
Fast Time to First Fix	
Cold Start	36s
Warm Start	36s
Hot Start	<1s
Sensitivity	
Tracking	-159 dBm
Acquisition	-159 dBm
Accuracy	
Horizontal Position (CEP)	2.5 m

3.8 Physical Details

The terminal's mechanical enclosure is a rugged, impact, and chemical resistant plastic material. All dimensions are shown in millimeters (mm).

Figure 18 IDP-680 Top View Enclosure Dimensions (mm)

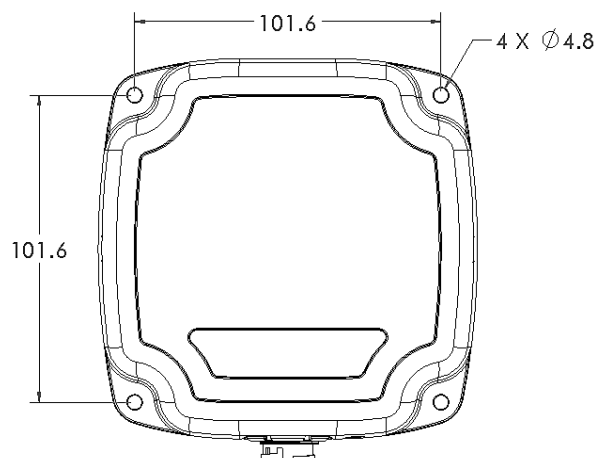

Figure 19 IDP-680 Side View Enclosure Dimensions (mm)

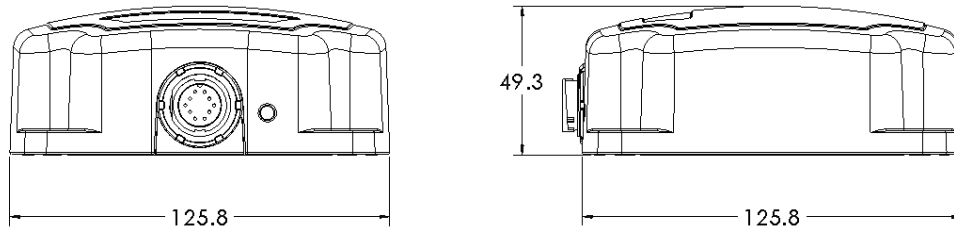

Figure 20 IDP-680 and IDP-690 Top View Enclosure Dimensions (mm)

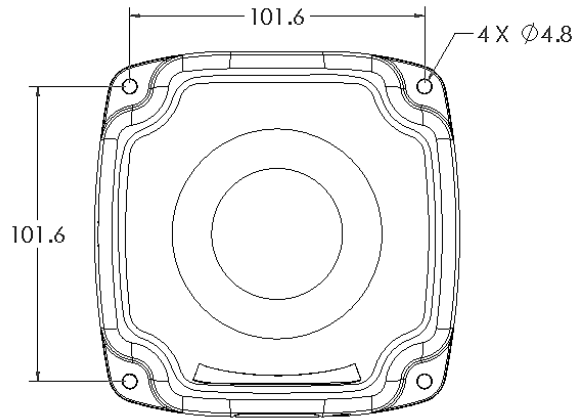

Figure 21 IDP-690 Side View Enclosure Dimensions (mm)

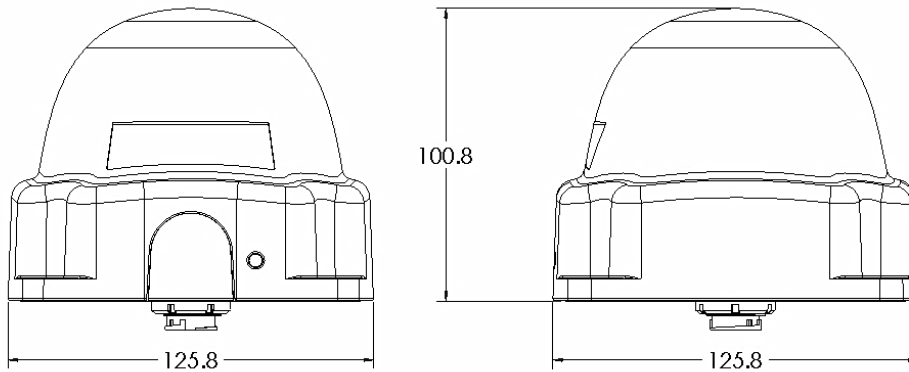

Figure 22 IDP 600 CID2 Series Bottom View Enclosure Dimensions (mm)

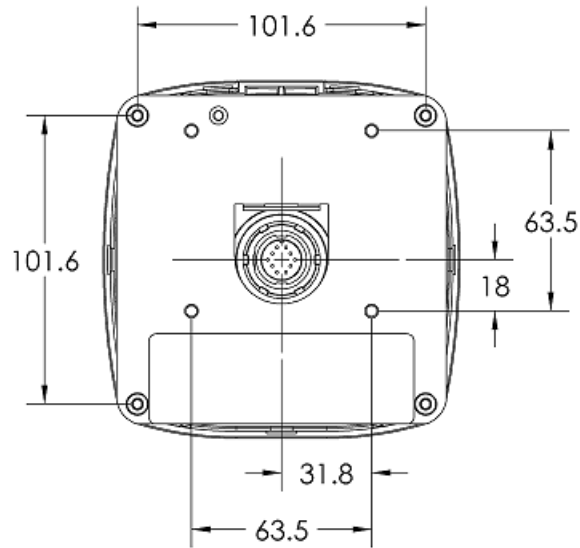

Figure 23 IDP-680 CID2 Side View Enclosure Dimensions (mm)

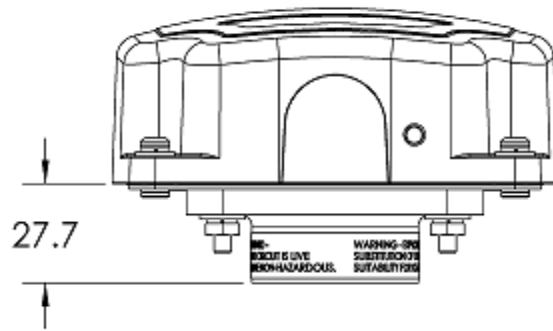
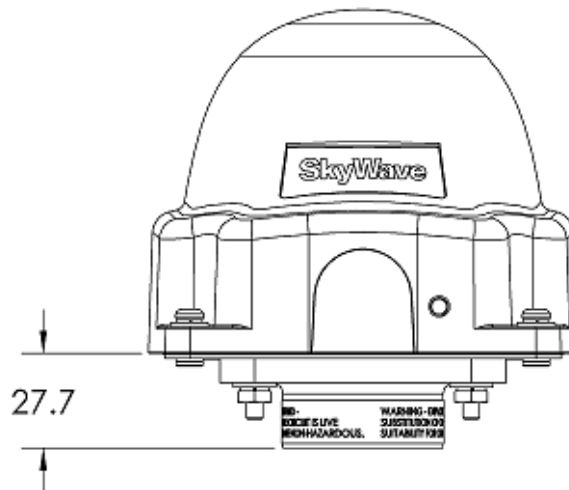

Figure 24 IDP-690 CID2 Side View Enclosure Dimensions (mm)



IDP 600 Series Terminals

Parameter	Value
IDP-680 or IDP-690 terminal mass	460 g
IDP-680 CID2 or IDP-690 CID2 terminal, including adaptor bracket with lance and threaded studs mass	595 g
Conduit adaptor with gasket mass	110 g
Strain relief assembly mass	25 g
Enclosure Material (CID2 terminals only)	Lexan EXL9330 Resin
Enclosure Material (non CID2 terminals)	Xenoy® 5220U Resin ⁷

3.9 LED

The terminal has an integral LED to indicate that the terminal has successfully powered up (Section 4.8). Refer to [T204] for further details.

Parameter	Value
Color	Red

3.10 Non-Volatile Storage

The IDP 600 series has non-volatile flash memory that is shared by the terminal firmware and user services.

Parameter	Value
Non-volatile On-board Flash Storage	4 MB
Write-Erase Cycles (per operating life)	100 000

⁷ For additional details, see <http://www.ides.com/PWeb/obds.aspx?E=15025>

3.11 Environmental

Temperature

Parameter	Value
Operating Temperature	-40° to +85°C
Storage Temperature	-40° to +85°C

IDP-680 and IDP-690

Parameter	Description
Humidity	The IDP-680 meets all its specifications during exposure to 90% relative humidity at +85°C, per the test methodology of SAE J1455, section 4.2.3.
Vibration	The IDP-680 meets all its specifications during exposure to random vehicular vibration levels per SAE J1455, section 4.9.4.2 and MIL-STD-810G, section 514.6, fig 514.6C-1.
Mechanical Shock	The terminal meets all its specifications after exposure to positive and negative saw tooth shock pulses with peaks of 20G and durations of 11 ms as specified in MIL-STD-810G, section 516.6, Procedure I, section 2.3.2c, 3/axis/(positive and negative direction).
Altitude	The terminal meets all of its specifications after a non-operating 12.2 km altitude test as detailed in SAE J1455, section 4.9.3, except with an ambient temperature of -40°C.
Thermal Shock	The terminal meets all of its specifications after a thermal shock test as detailed in SAE J1455, section 4.1.3.2.
Salt Spray Atmosphere	The IDP-680 meets all of its specifications after a salt spray test as detailed in SAE J1455, section 4.3.3.1.
Immersion	<p>The terminal meets all of its specifications after a 6 hour alternating hot/cold salt water immersion test as detailed in SAE J1455, section 4.3.3.2.</p> <p>The terminal meets all of its specifications after a 30 minute, 1 m depth fresh water immersion test as detailed in IEC 60529, section 14.2.7.</p> <p>These immersions were performed without a cable mating with the circular connector.</p>
Exposure to Chemicals and Oils	<p>The terminal meets all of its specifications after a light to moderate splash test as detailed in SAE J1455 section 4.4.3.2, for the following chemicals:</p> <ul style="list-style-type: none"> • Window Washer Solvent • Gasoline • Diesel Fuel • Fuel Additives • Alcohol

Parameter	Description
	<ul style="list-style-type: none"> • Anti-Freeze Water Mixture • Degreasers • Soap and Detergents • Steam • Waxes • Kerosene • Freon • Spray Paint • Paint Strippers • Ether • Dust Control Agents (magnesium chloride) • Moisture Control Agents (calcium chloride) • Ammonia • Aluminum brightener (acid wash)
Steam Cleaning and Pressure Washing	The terminal meets all of its specifications after a steam cleaning and pressure wash test as detailed in SAE J1455, section 4.5.3.
Fungus	The terminal meets all of its specifications after a fungus test as detailed in SAE J1455, section 4.6.3.
Dust and Sand Bombardment	The terminal meets all of its specifications after a dust and sand bombardment test as detailed in SAE J1455, section 4.7.3. The terminal meets the acceptance conditions of IEC 60529, section 13.6.2 after a dust and sand bombardment test as detailed in IEC 60529, section 13.4.
Drop Test	The terminal meets all its specifications after a handling drop test as specified in SAE J1455, section 4.11.3.1.
ESD	The terminal meets all its specifications after exposure of the enclosure to 6 kV ESD contact discharge per IEC 61000-4-2, level 3.

3.12 Temperature Sensor

Parameter	Value
Range	-40 to +85°C
Accuracy	±2°C (-25 to +85°C) ±3°C (below -25°C)

THIS PAGE INTENTIONALLY LEFT BLANK

4 Installation

The following section contains SkyWave's recommended installation guidelines for the Solution Provider (SP). These recommendations should be incorporated into installation guidelines for end users.

CAUTION



The installer is responsible for injury or damages as a result of the installation, except any such injury or damages arising solely from a defective SkyWave product. In addition to the liability imposed upon the installer on the account of personal injury, bodily injury, including death, or property damage suffered as a result of the installer's installation of the product, the installer assumes the obligation to save harmless SkyWave, including its agents, employees and assigns, and to indemnify SkyWave, including its agents, employees and assigns, from every expense, liability or payment arising out of such wrongful or negligent act or omission, including legal fees. The installer also agrees to hold harmless SkyWave, including its agents, employees and assigns, from any wrongful or negligent act or omission committed by any subcontractor or other person employed by or under the supervision of the installer for any purpose, and to indemnify SkyWave, including its agents, employees and assigns, from every expense, liability or payment arising out of such wrongful or negligent act or omission.

The terminal uses very low power during transmission and therefore presents no radiation hazard during normal use, installation, testing, and troubleshooting.

4.1 Getting Started

Getting the terminals ready for operation requires doing the following:

1. Prepare for the installation (Section 4.2)
2. Identify the fuse panel location (Section 4.3)
3. Determine a suitable mounting location (Section 4.4)
4. Route the main cable (Section 4.5)
5. Mount the terminal (Section 4.6)
6. Protect the cables and cable connectors (Section 4.7)
7. Connect to power (Section 4.8)
8. Register the terminal (Section 4.9)

4.2 Prepare for the Installation

Check that you have the items and tools listed below before installing the terminal.

4.2.1 Shipping Box Contents

Unpack the contents of the shipping box and use the list below as a guide to check that you received the items you ordered.

- IDP-680, IDP-690, IDP-680 CID2, or IDP-690 CID2 terminal
- Mating cable connector kit
- Tube of dielectric grease (e.g., silicone lubricant)
- Installation Guide
- Optional kits (APPENDIX A)
- Conduit adaptor, strain relief bracket , and cable ties (CID2 terminals only)

4.2.2 Mobile Identification

Each mobile device has a unique mobile ID used by SkyWave to register it on the IsatData Pro network. This is a 15-digit alphanumeric identifier in the format NNNNNNNNSKYXXXX. The mobile ID is located on the bottom of the terminal and on the shipping box.

Figure 25 Mobile ID Location

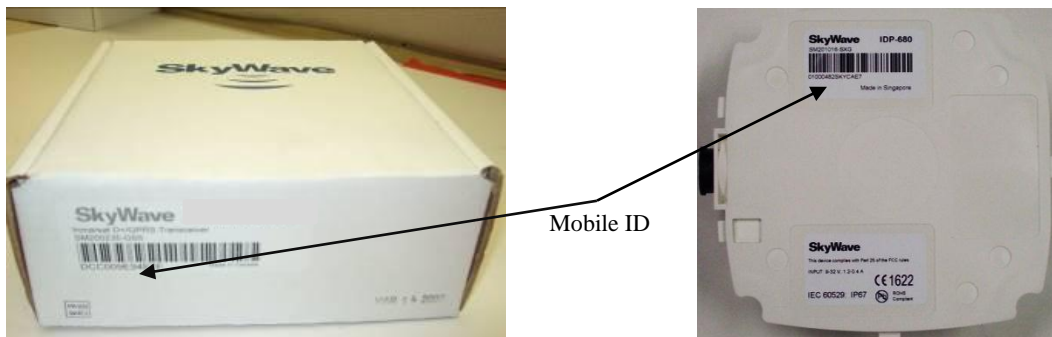

1. Record the mobile ID in APPENDIX E for future reference.

Note: *SkyWave may activate terminals on the network prior to or after shipping based on the Purchaser (SP) agreement.*

4.2.3 Contact SkyWave to Activate the Terminal

In order to send or receive any message you must activate the terminal on the IsatData Pro network.

1. Send an email to support@skywave.com to request account and terminal activation.
2. Provide the terminal's mobile ID.

Keep a copy (APPENDIX E) of the terminal's mobile ID along with the server access ID and password you receive in the email from SkyWave Customer Support. You need these to communicate remotely with the terminal.

Figure 26 Sample Activation Report

SkyWave SkyWave Support

Report

Report: Active Control Stations and Terminals
 Report generated: May-24-2011 14:57
 Report period: Current

Control Stations/Access IDs

Solution Provider: **SkyWave Internal**
 Solution Provider ID:

Gateway Account Name: **SkyWave Support**
 Gateway Account ID:

Access ID and password required to securely access your messages over the Internet

Access ID	Password	Activation Date
70000009		May-03-2011 15:09

Terminals/Devices

Solution Provider: **SkyWave Internal**
 Solution Provider ID:

Gateway Account Name: **SkyWave Support**
 Gateway Account ID:

Mobile/Broadcast ID	Mode	Feature Code	Description	Status	Activation Date
010001095KV6F9E	IsatData Pro	0x0002		Activated	May-23-2011 01:30
010001685KVDC5	IsatData Pro	0x0002		Activated	May-03-2011 19:09
16777201GR931F2	IsatData Pro		Customer Support Broadcast	Activated	May-12-2011 13:37

The Mobile ID is the serial number which appears on the mobile device and is used to uniquely identify the device when sending and receiving messages

4.2.4 Required Tools and Materials

You require the following tools materials to install a terminal. These do not ship with the terminal.

Non IDP CID2 Terminals

- Qty 4 - M4 (8-32) 18-8 stainless steel screws (length depends on mounting surface thickness)
- Qty 4 - M4 (8-32) nuts with 18-8 stainless steel flat and lock washers
- Waterproof sealing tape
- Waterproof sealing compound such as RTV silicone (bottom connector version only)
- Custom cable⁸
- Drill
- 5.5 mm drill bit
- 30 mm diameter hole punch or hole saw (bottom connector version only)
- Screwdriver

⁸ Refer to Section 5 for instructions on making a custom cable.

- Socket wrench set

IDP CID2 Terminals Only

- Socket or open-end wrench set
- CID2 hazardous location approved wiring enclosure, conduit and fittings/connections

Note: *The adaptation of the terminal to conduit or other enclosure must comply with local requirements for hazardous location equipment. At a minimum all connections must maintain NEMA Type 4 protection of the cable route and associate connections.*

SkyWave recommends that the Solution Provider supply the end-user with a custom built cable.

The CID2 terminal comes with an aluminum conduit adaptor with a standard 1/4" female thread. The Installer is responsible for integrating the terminal into an installation that meets the local code requirements for hazardous locations.

4.3 Identify the Fuse Panel Location

For installation in a truck, the cable from the terminal connects to the truck's fuse panel for power.

1. Locate the fuse panel in the truck. The location depends on the type, age, and model of the truck.
2. Identify an un-switched vehicle power source within the fuse panel for terminal power.
3. Ensure that the cable you ordered is of sufficient length to reach from the fuse panel to the final mounting location of the terminal.

4.4 Determine a Suitable Mounting Location

Before installing the terminal, consider the important guidelines provided below.

CAUTION  *Most users install the terminals on a vehicle. It is very important for installers to install the terminals in a safe and secure way to avoid danger or damage to persons or property.*

- Mount the terminal where it has a clear view of the sky/satellite. For a mobile installation, this means at the highest point on the vehicle or vessel where it has a clear view of the sky in all directions.
- Mount the terminal so that the Inmarsat satellite is within α degrees of the mounting surface, $\alpha = 0$ to 90 degrees for all IDP-680 terminals and -15 to 90 degrees for all IDP-690 terminals. Make sure that the line of sight is clear of obstructions.
- Mount the terminal on a flat surface for mobile installations such that the elevation angle does not change with rotation.

Note: *For fixed installations, the terminal can be pointed at the Inmarsat satellite to improve performance. This is not necessary for IDP-690 terminals.*

- Fasten the terminal securely so that it is not loose and does not move easily.

- Mount the terminal on a solid, stable surface. If necessary, use a mounting bracket (not supplied) or other suitable support.
- Mount the terminal so that the top surface is horizontal (flat). Failure to do so may compromise line of sight between the satellite and the terminal.
- Mount the terminal on a surface that does not get hotter than the maximum operating temperature. If the surface may get hotter, mount the terminal with a thermal barrier between it and the mounting surface.

CAUTION *Mount the terminal at least
20 cm away from humans.*





- Do not mount the terminal close to other electrical equipment due to possible radiated and/or conducted electromagnetic interference.
- Do not mount the terminal close to radar or other communications antennas. Use the following guidelines:
 - > 1 m from VHF/UHF antenna
 - > 3 m from loop antenna
 - > 4 m from MF/HF antenna
 - > 5 m from other satellite antennas
 - Not within a radar beam
- Do not mount the terminal where water may build-up or collect.
- Ensure that any paint above the terminal is non-metallic and non-metallic flake, if the installation is under fiberglass or composite wind fairings.
- Check that the terminal's cable reaches the power source before you drill any mounting holes.
- Do not mount the terminal close to an exhaust pipe due to the excessive heat and the potential for the exhaust pipe causing satellite blockage.
- Do not mount the terminal close to air horns or any tractor roof hardware (e.g., emergency lights) that could interfere with satellite communications.
- Mount the terminal on the driver's side of the vehicle, if possible, when there is a possibility of strikes by overhanging tree branches.
- Do not install the terminal inside the truck under the roof liner.
- Ensure the IDP-680 CID2 or IDP-690 CID2 mounting surface is capable of mechanically supporting the terminal. It is recommended that the terminal be mounted on an NEMA Type 4 enclosure qualified for use in hazardous locations as required for the specific application. A Galvanized Rigid Conduit (GRC) or Electrical Metal Tubing (EMT) tubing and/or metal GRC/EMT conduit fitting may be used to adapt the terminal.

Once you have picked the mounting location, mount the terminal (refer to Section 4.5).

4.5 Route the Main Cable

Consider the following guidelines before routing the cable assembly.

CAUTION  *Ensure the power cable will not be pinched, kinked or worn down by any objects or moving parts such as the door hinges. It is very important to secure the cable at many points along its path.*

CAUTION  *Prior to working on any cabling, ensure that the terminal is powered off and will not start while work is in progress.*

- Do not route the cable near the engine if routing through the engine compartment. This location can subject the cable to extreme heat.
- Keep the cable away from hot surfaces such as exhaust pipes as this may damage the cable.
- Do not run the cable over sharp or jagged edges.
- Place the cable in recesses and channels, whenever possible, to prevent potential damage or wear by foot traffic.

Note: *Remember to leave enough cable slack near the terminal for strain relief so as not to introduce any additional force on the connector. SkyWave recommends securing the cables during installation.*

Figure 27 Sample Cable Placement in a Vehicle Cab



Run the cable assembly following the steps below.

1. Use tape to temporarily secure the terminal in its final location while you run the cable.

CAUTION  *Do not drill any mounting holes at this time.*

2. Search for vehicle cab entry points on the side of the vehicle closest to the fuse panel. This helps to minimize the amount of cable routed along the floor of the cab.

Where possible route the cable through existing holes in the floor or the firewall of the engine compartment.

3. Route the cable starting from the terminal to the fuse panel or battery source.

Note: SkyWave recommends that you tape cable ends to prevent dirt from collecting on the contacts.

4.6 Mount the Terminal

These instructions apply to non-CID2 terminals. Refer to APPENDIX G for CID2 instructions.

CAUTION *Painting terminals or antennas may interfere with their performance.*



The terminal either has a bottom connector or a side connector.

Note: The Solution Provider is responsible for providing mounting instructions if the mounting is to be done using tools or configurations that are different from the ones described in this document.

Note: It is the installer's responsibility to comply with local electrical codes.

Figure 28 Bottom Connector and Side Connector (IDP-680 shown)

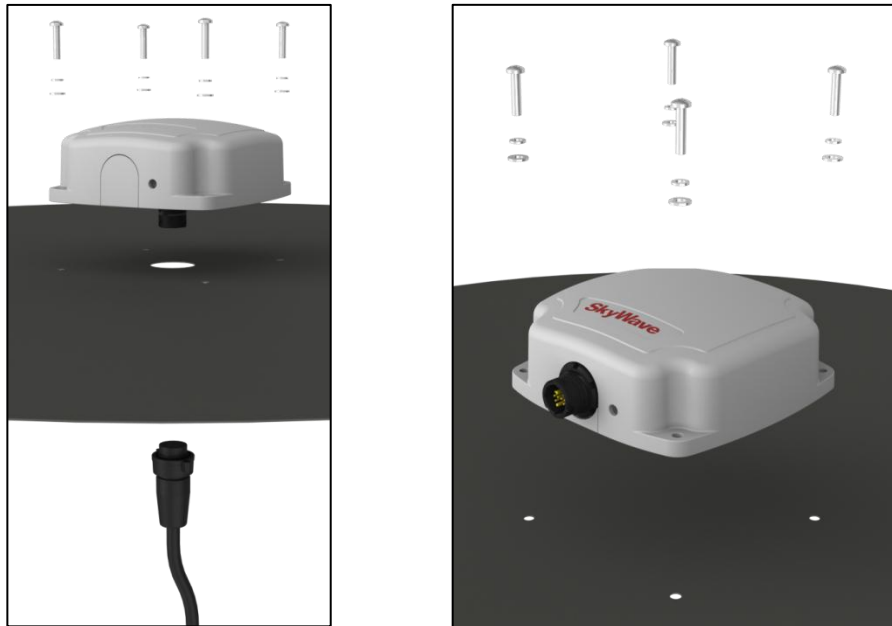

If installing an IDP-680 CID2 or IDP-690 CID2 terminal in a hazardous environment, refer to APPENDIX G before mounting the terminal.

4.6.1 Drill Mounting Holes (optional)

Note: These steps are only needed if you do not require a mounting bracket (provided by the Solution Provider).

1. Use the drill template (APPENDIX F) to mark the location of the four mounting holes and the connector hole. The direction of the terminal with a bottom connector is not important.
2. Drill the four mounting holes using the drill with the 5.5 mm bit.
3. Punch or drill the 30 mm hole for the connector (bottom connector only).

4. Continue with the steps, below, for Mount the Terminal.

4.6.2 Mount the Terminal

1. Apply waterproof sealing compound, such as RTV silicone, to the locations shown in Figure 29 (bottom connector only).

Optional: You can also apply waterproof sealing compound to the drilled mounting holes before inserting the screws.

Figure 29 Location for Waterproof Sealing Compound

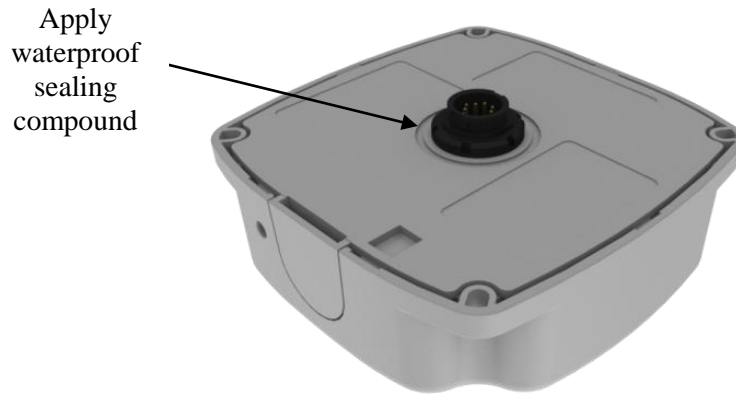

2. Use the screwdriver and socket set to lock the terminal in place with the mounting hardware.

CAUTION *Do not over-tighten.*



4.6.3 Apply Dielectric Grease

1. Cut off one end of the tube of silicone lubricant (Figure 30). Adding the silicone lubricant (grease) ensures that there is a watertight seal.
2. Insert the tube into the male end of the mating connector (Figure 30).

CAUTION *Do not apply pressure to the cable/connector during the installation.*



Figure 30 Apply Silicone Lubricant to Connector

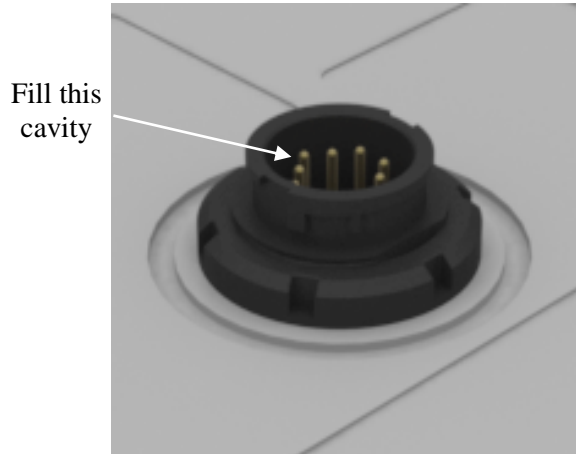

3. Squeeze the lubricant into the mating connector opening until it is full. Some lubricant may spill out.
4. Connect the cable connector to the terminal by aligning the corresponding connector key slot (Figure 31) and gently squeezing together.

CAUTION *Do not force the connector pins to mate since this may damage the pins.*



Figure 31 Key Slot

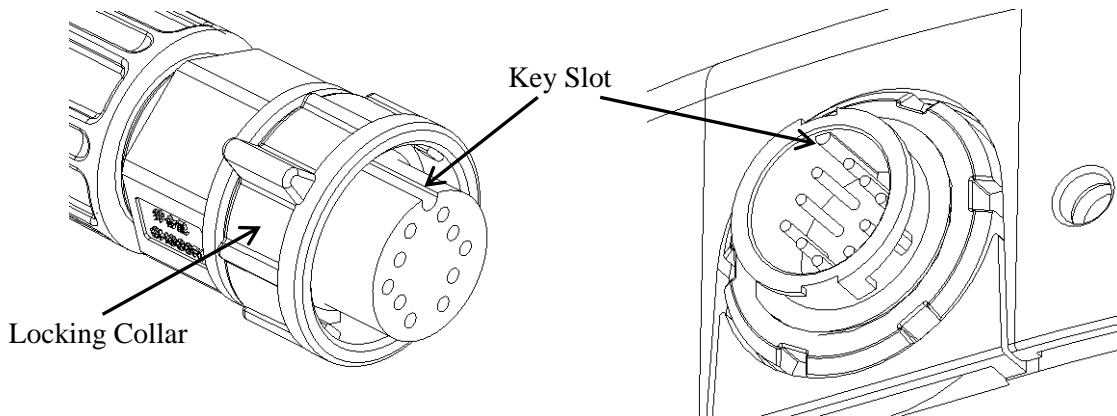

5. Tighten the cable connector with hand pressure by rotating the locking collar on the cable connector clockwise. **Do not use a wrench.** A tactile click is felt when the collar is properly engaged.

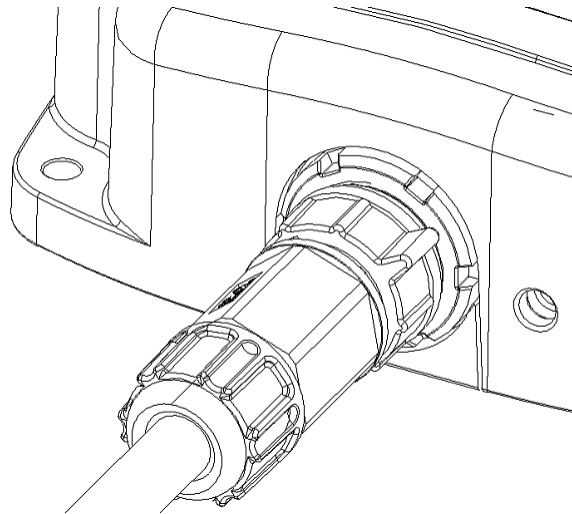
Figure 32 Cable Connector and Locking Collar

6. Wipe off any extra lubricant around the connector.
7. Wrap the mating connector with waterproof sealing tape if using the connector in changing weather conditions.

4.7 Protect the Cables and Cable Connectors

CAUTION  *Cable management and connector strain relief must be incorporated in the installation. SkyWave highly recommends securing the cable at regular intervals along its length as part of the installation to prevent cable wear and eliminate strain on the terminal connector. Damage to the terminal connector interface or cable may otherwise result leading to hardware failure.*

To protect the terminal's connector interface, follow the guidelines below:

- Apply tape around the cable ends to help in routing the cable.
- Secure the cable such that it does not pull on the connector or strain the terminal connector.
- Tie the cable down so that the weight of a vibrating cable does not stress or strain the connection.
- Tie the cable down using cable ties and tie holders (Figure 33) at 300 to 600 mm intervals along the cable route to prevent chafing, wear, or strain.
- Secure the cable tie holder with a self-tapping screw (Figure 33) for best holder retention.

Figure 33 Cable Management

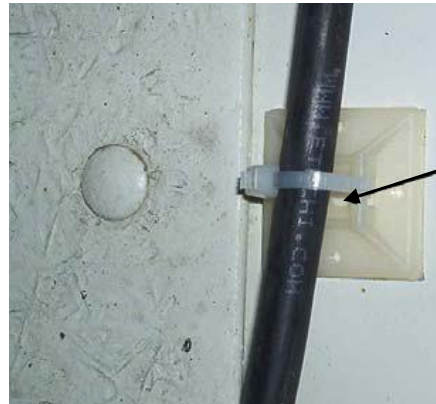

Adhesive cable tie holder. Apply a self-tapping screw here for added strength.

4.8 Connect to Power

CAUTION *Apply power only after making ground connection.*



CAUTION *Before applying power to the terminal, make sure that your power supply's rated voltage follows the recommended values specified in Section 2.*



CAUTION *The installer is responsible for complying with local electrical codes.*



Warnings below are for IDP 600 series CID2 terminals only

WARNING *This equipment is suitable for use in Class I Division 2 (CID2), Groups A, B, C and D locations or non-hazardous locations only.*



WARNING *Explosion hazard – Do not connect or disconnect equipment unless power has been switched off or the area is known to be non-hazardous.*



AVERTISSEMENT – Risque d'explosion – Avant de connecter ou de déconnecter l'équipement, couper le courant ou s'assurer que l'emplacement est désigné non dangereux.

WARNING *Explosion hazard – Substitution of components may impair suitability for Class I, Division 2.*



AVERTISSEMENT – Risque d'explosion – La substitution de composants peut rendre ce matériel inacceptable pour les emplacements de Class I, Division 2.

Note: *SkyWave recommends that if possible the user wait until the terminal is unblocked (i.e., has a full view of the sky) before powering up the terminal.*

1. Locate the main power input and the ground (GND) wires on the cable breakout.

You can connect the terminal ground to ground in the fuse panel or to chassis ground. To do this, secure the ground wire on the cable assembly to a piece of metal electrically connected to the vehicle chassis using a sheet metal screw.

2. Ensure that the main power input and ground wires reach the vehicle fuse panel. If the wires are not long enough, splice similar gauge wire to the main power input and ground wires so that they reach the fuse panel. Cover any splices with adhesive lined heat shrink.
3. Connect the ground wire to the grounding point selected in Section 4.3.
4. Connect the main power input wire to the un-switched vehicle power source within the fuse panel.
5. Loop and secure any excess cabling.

When connected to an external power source, the terminal gives an indication that it has power when the LED lights up.

Figure 34 LED Location

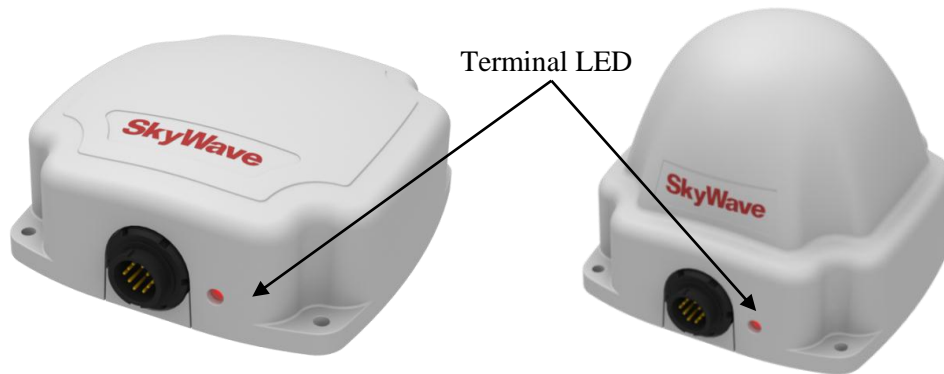

If your application requires extended cable lengths, it is necessary to calculate the cable voltage drop to determine if the terminal is receiving at least 9 V (with 1.7 A draw). Large cable voltage drops may adversely affect terminal operation.

Note: *Connect only SkyWave approved cables to the terminal. Use of other cables voids the terminal warranty.*

4.9 Register the Terminal

Note: *The IDP 600 series terminals must complete registration to operate.*

Once you apply power, the terminal goes into satellite search mode to acquire the SkyWave IsatData Pro network. This activity may take a few minutes to complete. If you experience difficulties, refer to Section 6 for troubleshooting suggestions.

1. Once the terminal synchronizes itself with the network, it sends a registration message to the SkyWave IsatData Pro network.

Note: *The terminal will not register until it has a clear line of sight to the satellite.*

2. The SkyWave IsatData Pro network records the registration message and forwards the registration message to the user's application.

The SkyWave IsatData Pro network sends an acknowledgement message over the satellite to the terminal. The terminal is now available to send and receive messages.

4.10 Cleaning Instructions

Wash the terminals with mild soaps or detergents.

4.11 Application Programming Interface

Refer to [T202] for programming information for the terminals.

THIS PAGE INTENTIONALLY LEFT BLANK

5 Cable Assembly Instructions

This section provides the information necessary for the Solution Provider to assemble IDP power/interface cables for the end-user. The solder cup cable connector kit ships with the terminal.

Note: *It is recommended you choose a raw cable with the following properties:*

** The terminal accepts input ranges of 9 to 32 VDC. If your application requires extended cable lengths, it is necessary to calculate the cable voltage drop to determine if the terminal is receiving at least 9 V (with 1.7 A draw). Large cable voltage drops may adversely affect terminal operation.*

** Cable jacket and internal conductor installation rated for minimum temperature range of -40°C to 85°C, and UV compliant where exposure to UV is expected.*

Note: *For reliable operation, shield all cables used for power and data connections to the terminal.*

Figure 35 Basic Connector Parts for Soldering Configuration



5.1 Required Tools and Materials

The following tools and materials are required to build the cable using this method:

- A cable⁹ appropriate for the terminal's environment
- A knife
- A wire stripper
- Solder
- A fine-tip soldering iron
- A flexible high temperature silicone sealant for outdoor exposure

5.2 Cable Assembly Steps

1. Use a knife to cut and remove the outer jacket of the cable, 20 mm from the end (Figure 36) and remove any foil shielding.

⁹ For cables exposed to extreme temperatures and sun, select a cable with a thermal rating of -40°C to +85°C and a UV resistant jacket.

CAUTION *Be careful not to nick the wire insulation.*

- Use a wire stripper to remove 5 mm of insulation from the wires (Figure 36).

Figure 36 Recommended Stripping Length

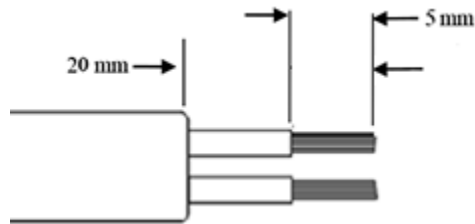

- Twist the ends tightly to prevent stranded wires from fraying.

CAUTION *Do not solder dip.*

- Slide the following items over the cable in sequence and as shown in Figure 37: a sealing nut, a back shell and a coupling ring.

Figure 37 Cable with Sealing Nut, Back Shell and Coupling Ring



CAUTION *Ensure that the black back shell cable grommet is present inside the cable grip area (Figure 38) and the red gasket is present and oriented with flat face visible as shown in Figure 39.*

Figure 38 Cable Grommet



Figure 39 Red Gasket

5. Using a soldering iron and solder, tin the wires and solder them to the connector solder cups (Figure 40) as per the proper pin-out.

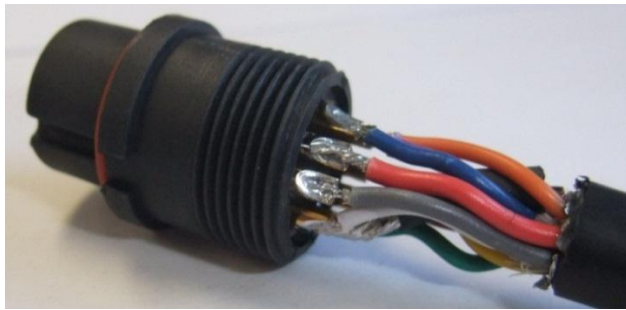
Figure 40 Wires and Solder Cups

6. Ensure the O-ring is in place over the connector body as shown in Figure 41.

Figure 41 O-Ring over Connector Body

7. Slide the coupling ring over the connector body and give it a twist to prevent it from falling off.
8. Use silicone sealant to completely fill the end of the connector and the area between the wires (Figure 42).

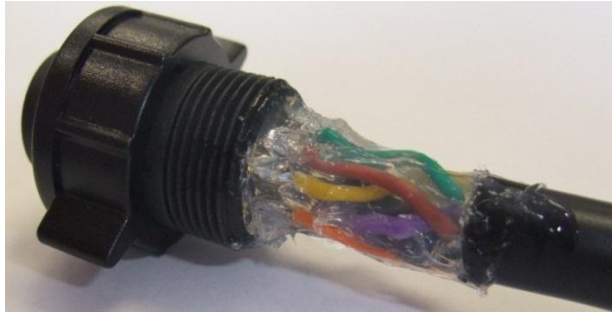
Figure 42 Silicone in the Connector

9. Slide the back shell up the cable as close as possible to the connector body and fill it with silicone sealant (Figure 43).

Figure 43 Silicone in the Grommet

10. Assemble the back shell to the connector body and wipe away any excess sealant (Figure 44). To aid in tightening the back shell, align the coupling ring key feature with the slot in the connector body (Figure 44).

Figure 44 Key Features in the Coupling Ring and Connector Body

11. Apply sealant over the cable exit area as shown in Figure 45.

Figure 45 Cable Exit Area

12. Assemble the sealing nut over the back shell until the cable grip makes full contact with the perimeter of the cable jacket (Figure 46). Wipe away any excess sealant.

Figure 46 Assembled Sealing Nut



THIS PAGE INTENTIONALLY LEFT BLANK

6 Troubleshooting the Terminal

The following section contains troubleshooting information for the Solution Provider (SP) to provide to end users.

6.1 Terminal Does Not Register or Report

On application of external power the terminal should register with the satellite and send a report.

Note: *The terminal must be visible to the satellite to register with the network and registration normally takes a few minutes.*

If the terminal fails to register or report:

- Ensure that the antenna has a clear line of sight to the satellite. The terminal must operate outdoors and be unobstructed by buildings, forest canopy, and rock cuts.
- Check that no objects or debris are on the antenna (i.e., atop the terminal) and blocking transmission.
- Verify with your SP that the terminal is assigned to your account and registered (i.e., that it is sending and receiving) and that the SkyWave IsatData Pro network is operating properly.
- Check the condition of the power cable.

Replace the device, if the above checks fail to uncover the problem.

THIS PAGE INTENTIONALLY LEFT BLANK

APPENDIX A Order Part Numbers

Table 10 Order Part Numbers

Terminal - Standard GPS	Part Number	
	Side Connector	Bottom Connector
IDP-680 with standard GPS (modem hardware # 3)	SM201016-SXG	SM201016-BXG
IDP-680 with hardware GPS (modem hardware # 4)	SM201085-SXG	SM201085-BXG
IDP-680 with standard GPS and CID2 approval (modem hardware # 3)	-	SM201079-BXG
IDP-690 with standard GPS (modem hardware # 3)	SM201009-SXG	SM201009-BXG
IDP-690 with hardware GPS (modem hardware # 4)	SM201087-SXG	SM201087-BXG
IDP-690 with standard GPS and IEC 60945 compliant (modem hardware # 3)	SM201075-SXG	SM201075-BXG
IDP-690 with standard GPS and CID2 approval (modem hardware # 3)	-	SM201080-BXG

Antenna	Part Number	
	Side Connector	Bottom Connector
IDP-180 remote antenna with 5m FAKRA connector	ST901065-AFX	-
IDP-190 remote antenna with 5m FAKRA connector	ST901066-AFX	-

Kits	
Mating Connector with Solder Cup Kit	SA901020-001
Pole Mount Kit	ST900503
Contact your Account Executive for additional products and ordering codes.	

APPENDIX B Activation Information

Server User Name: _____

Password: _____

Terminal Type/ Description	Mobile ID (NNNNNNNNSKYXXXX)	Location

APPENDIX C IDP 600 Series Blunt Cut Cable

This cable connects the IDP terminal to external I/O lines and serial ports. There are a total of ten pins on this blunt cut cable; two connect the terminal to an RS-232 console serial port or an RS-485, four wires to connect to external I/O lines, and one each for ground and voltage. The cable has an over-molded connector, a floating drain wire and is available in two models, either terminated or un-terminated to ground.

Figure 47 IDP 600 Series Blunt Cut Cable



Specifications

Parameter	Value
Part Number: ST301005	Cable drain wires (outer shield and I/O - Figure 49) terminated to ground at IDP terminal connector (PIN 3 - Figure 48).
Part Number: ST301025	Cable drain wires un-terminated/not connected (outer shield and I/O - Figure 49) to ground.
Length	ST301005-001 5 m (16.5 ft.) ST301005-002 10 m (32 ft.) ST301005-003 25 m (82 ft.) ST301025-004 25 m (82 ft.) For additional lengths, contact your Account Executive.
Temperature	-40°C to +85°C
Ultraviolet rating	UV stabilized

Figure 48 Face View of IDP 600 Series Blunt Cut Cable Connector

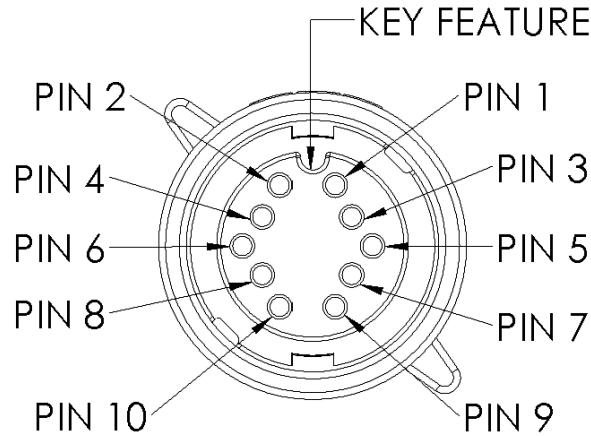
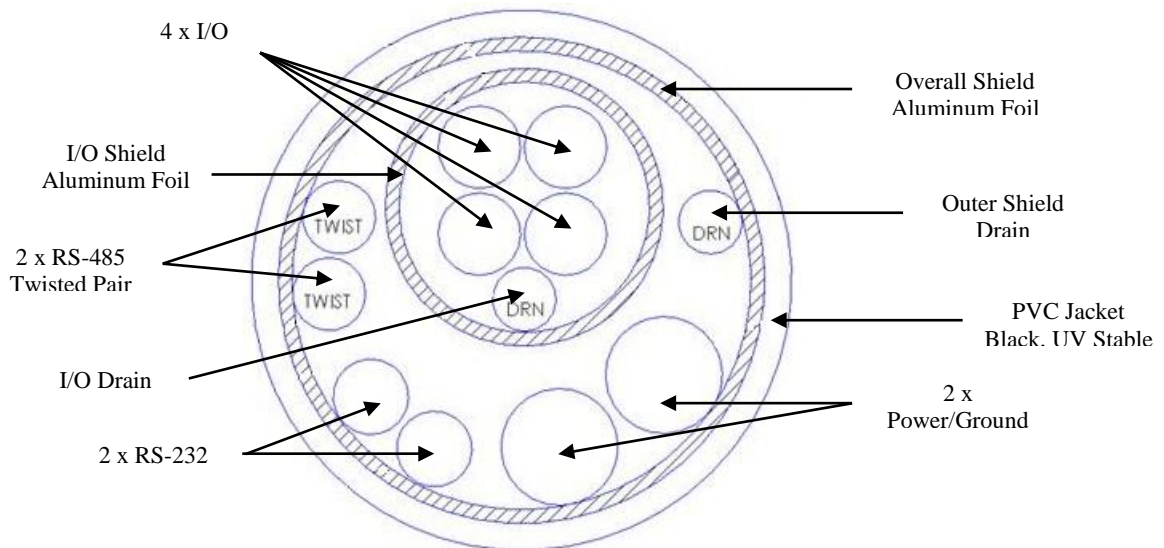

Table 11 IDP 600 Series Mating Blunt-Cut Cable Color Code

Position	Color	Wire Gauge	Functionality
1	White	22 AWG	RS-485_A
2	Grey	22 AWG	RS-485_B
3	Black	20 AWG	Ground
4	Red	20 AWG	VIN (Vbatt)
5	Green	22 AWG	I/O 02
6	Blue	22 AWG	I/O 03
7	Brown	22 AWG	I/O 01
8	Purple	22 AWG	I/O 04
9	Orange	22 AWG	RS-232 Tx (output)
10	Yellow	22 AWG	RS-232 Rx (input)

Figure 49 Raw Cable Details



APPENDIX D IDP 600 Series to DMR-800 Adaptor Cable

This cable (ST301006-001) allows an IDP 600 series terminal to be installed in place of a DMR-800. The cable has eight connectors and the RS-485 connections on the IDP 600 series terminal are left unconnected.

Figure 50 IDP 600 Series to DMR-800 Adaptor Cable



Specifications

Parameter	Value
Length	0.6 m (2 ft.)
Temperature	-40°C to +85°C
Material	PVC jacket, 30 mils thick, black
Ultraviolet rating	UV stabilized

Figure 51 IDP Connector End Pin-Out

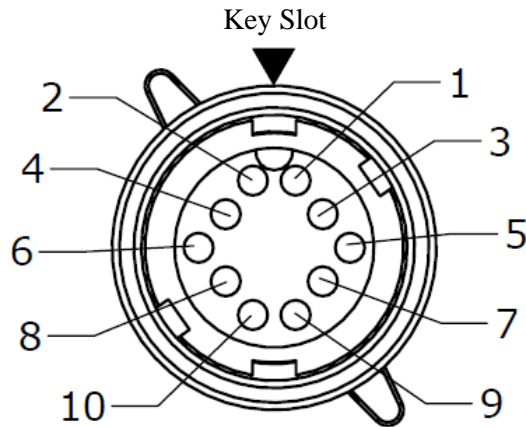

Figure 52 DMR-800 Mating Connector End Pin-Out

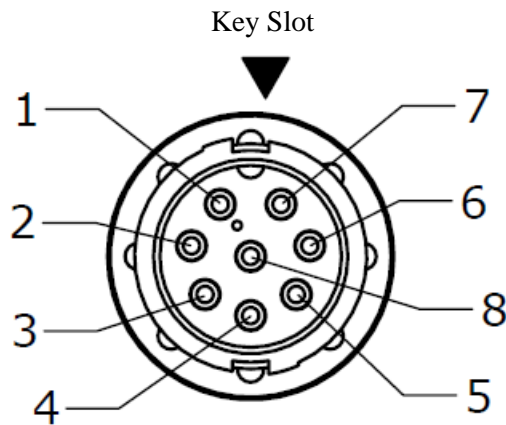

Table 12 Cable Connector Pin-Out

IDP Position	DMR-800D Position	Wire Gauge
1	N/C	-
2	N/C	-
3	4	18 AWG
4	5	18 AWG
5	6	20AWG
6	7	20 AWG
7	1	20 AWG
8	8	20 AWG
9	2	20 AWG
10	3	20 AWG

APPENDIX E IDP 600 Series Extension Cable

This cable (ST301017-001) allows an IDP 600 series terminal to be installed in place of a DMR-800.

Figure 53 IDP 600 Series Extension Cable



Specifications/Guidelines

Parameter	Value
Length	5 m (16.5 ft.)
Temperature	-40°C to +85°C
Material	PVC jacket, 30 mils thick, black
Ultraviolet rating	UV stabilized cable jacket
Rating	IP67 when mated
Minimum bend radius	25 mm

CAUTION *Cable management and connector strain relief must be incorporated in the installation. SkyWave highly recommends securing the cable at regular intervals along its length as part of the installation to prevent cable wear and eliminate strain on the connector. Damage to the connector interface or cable may otherwise result leading to hardware failure.*

Table 13 Cable Connector Pin-Out

Cable End A Position	Cable End B Position	Wire Gauge	Functionality
1	1	22 AWG	RS-485_A
2	2	22 AWG	RS-485_B
3	3	20 AWG	Ground
4	4	20 AWG	VIN (Vbatt)
5	5	22 AWG	I/O 02
6	6	22 AWG	I/O 03
7	7	22 AWG	I/O 01
8	8	22 AWG	I/O 04
9	9	22 AWG	RS-232 Tx (output)
10	10	22 AWG	RS-232 Rx (input)

Figure 54 Raw Cable Details

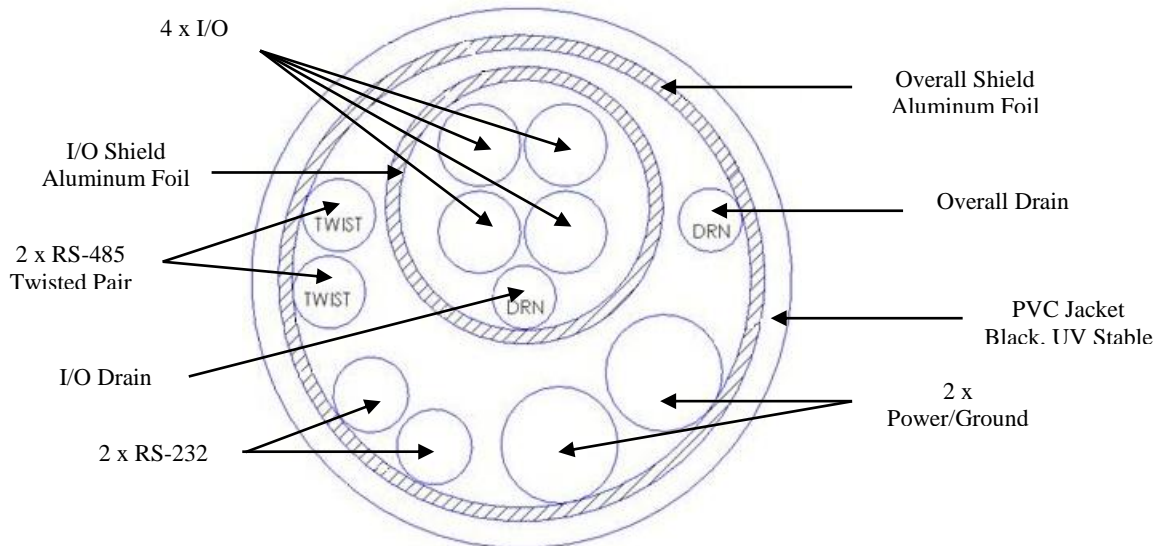

APPENDIX F Installation Instructions for a Pole Mount Kit

Below are the instructions to mount a low elevation terminal vertically on a pole or horizontally on a rail. The kit can accommodate a pole or rail between 57 and 80 mm (2 ¼" - 3 ⅛") in diameter. The pole or rail must be of sufficient height to have line-of-sight to Inmarsat satellites.

This guide provides information required for a successful installation of the pole mount kit only. For terminal installation instructions refer to installation guide appropriate for your type of terminal.

Shipping Box Contents

SkyWave ships the Pole Mount with the following parts.

- Pole mount bracket¹⁰ - qty 1
- Clamps¹¹ (high torque 18-8 stainless steel) - qty 2
- Cable ties (UV stable) - qty 2
- Screws (8-32 x ½", pan head, Phillips, 18-8 stainless steel) - qty 5
- Flat washers (#8, flat, 18-8 stainless steel) - qty 5
- Lock washers (#8, split, 18-8 stainless steel) - qty 5
- Installation instructions - qty 1

Required Tools and Materials

Installation of the pole mount kit requires the following tools and materials. These items do not ship with the kit.

- A torque screwdriver with N-m (in-lbs) setting
- Cutting pliers
- A 5/16" socket, nut driver or slotted screwdriver
- Waterproof sealing compound
- Waterproof sealing tape
- Terminal (including silicone lubricant)
- Terminal cable

Installation Steps

1. Select a mounting location as per the installation instructions for your type of terminal.

¹⁰ The pole bracket shipped in the kit can accommodate up to 16 mm (5/8") wide clamps.

¹¹ Clamps shipped in the kit can accommodate pipe diameters of 57 to 80 mm (2 ¼ to 3 ⅛").

2. Attach the self-adhesive sticker found in the pole mount kit to the underside of the pole mount bracket. Write the terminal's mobile ID/serial number on the sticker so it is visible for future reference.
3. Cut off one end of the tube of silicone lubricant (Figure 55) (ships with the terminal). Adding the silicone lubricant (grease) ensures that there is a watertight seal.
4. Insert the tube into the male end of the mating connector (Figure 55).

CAUTION *Do not apply pressure to the cable/connector during the installation.*

Figure 55 Silicone Lubricant and Connector



5. Squeeze the lubricant into the mating connector opening until it is full. Some lubricant may spill out.
6. Insert pan head screws, lock washers, and flat washers from the terminal side (Figure 56).
7. Screw the terminal to the bracket (four locations) (Figure 56).

Figure 56 Bracket and Screws

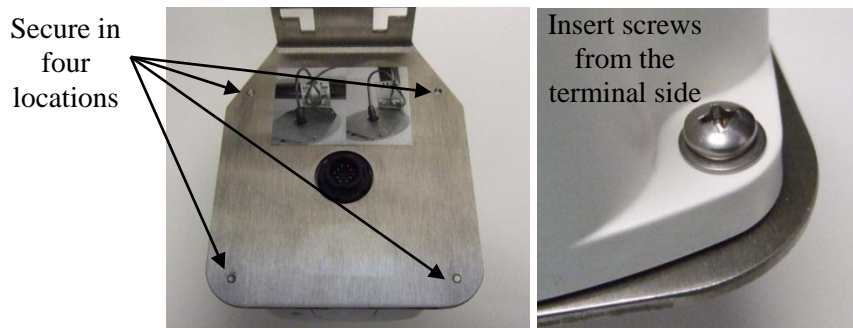

8. Torque screws to 1.4 N-m (12 in-lbs).
9. Position the terminal and bracket against the pole or rail as per the orientation shown in Figure 3.

Figure 57 Bracket Orientations

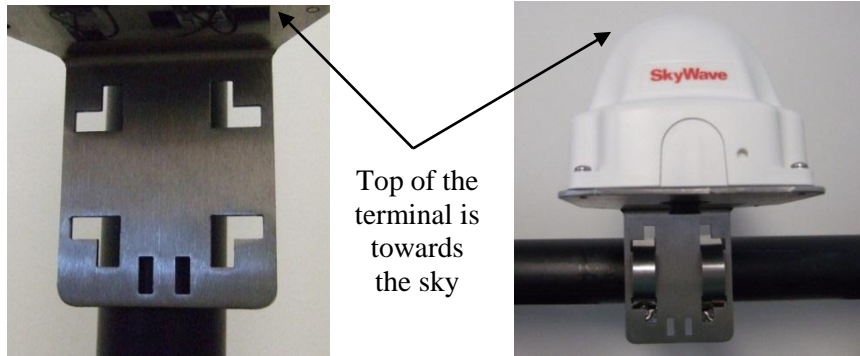

Vertical Mount Orientation

Horizontal Mount Orientation

10. Open the two clamps and feed them around the pole or rail and through the slots (Figure 58) in the bracket.
11. Position the clamp screw assembly behind the mounting bracket as shown in Figure 58.

Figure 58 Feed the Clamps through the Slots

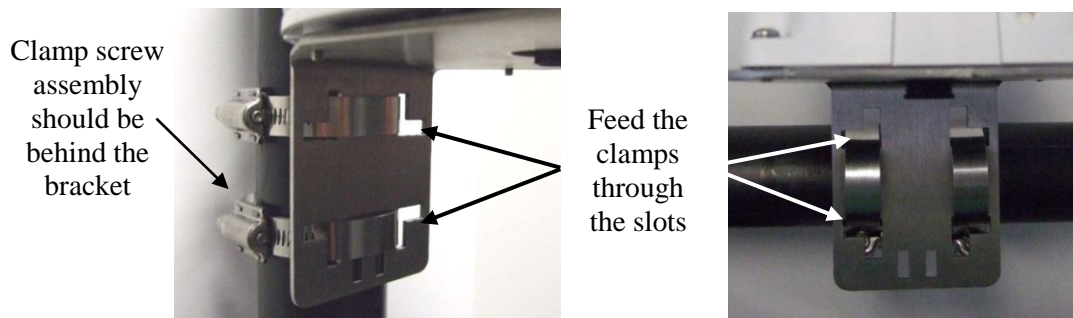

Vertical Mount Orientation

Horizontal Mount Orientation

12. Tighten each clamp to 3.4 N-m (30 in-lbs) with a 5/16" socket, nut driver, or slotted screwdriver (Figure 59). As you tighten the clamp it gets smaller. Do not cut the clamp.

Note: *Once the clamps are tightened, the bracket should not move on the pole if shaken back and forth.*

Figure 59 Tighten the Clamps



13. Connect the cable connector to the terminal by aligning the corresponding connector key slot and gently squeezing together (Figure 60).

14. Tighten the cable connector with hand pressure by rotating the locking collar on the cable connector clockwise. Do not use a wrench. A tactile click is felt when the collar is properly engaged.
15. Wipe off any extra lubricant around the connector.
16. Wrap the mating connector with waterproof sealing tape if using the connector in changing weather conditions.

CAUTION *Remember to leave enough cable for strain relief so as not to introduce any additional force on the connector.*

17. Ensure that the cable exits straight out of the terminal connector (Figure 60).

Figure 60 Cable Exit

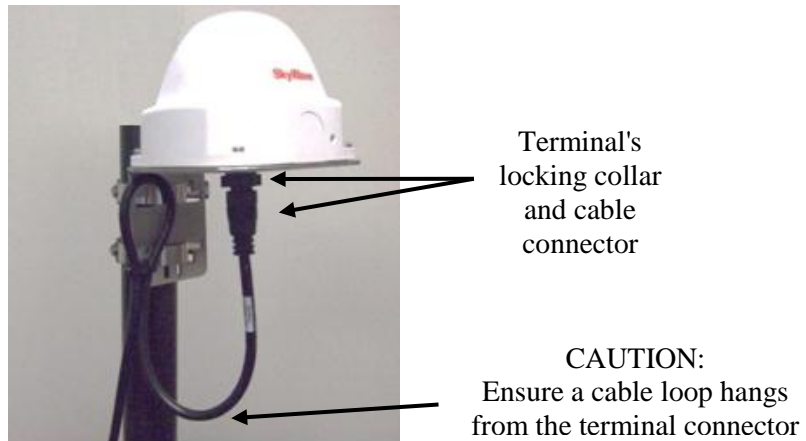

18. Route the cable as shown in Figure 61.

Figure 61 Secure the Cable

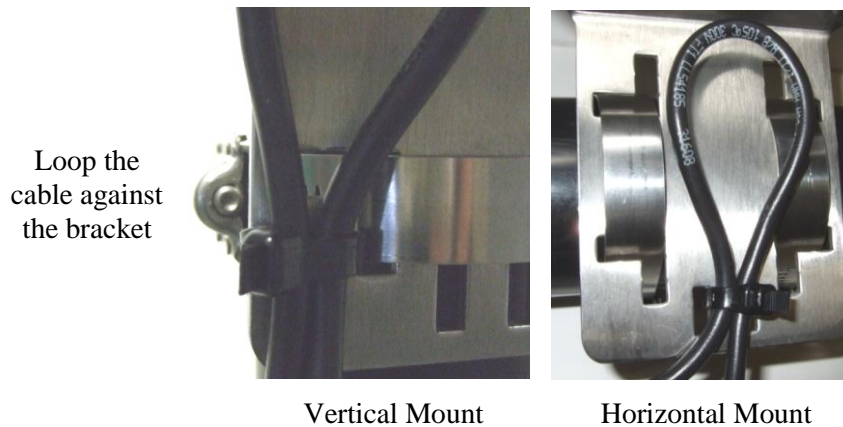

19. Insert a cable tie through slot in the bracket (Figure 61) and then tighten. This reduces strain on the cable connection.
20. Cut off any excess cable tie length (Figure 62).

Figure 62 Tie the Cable

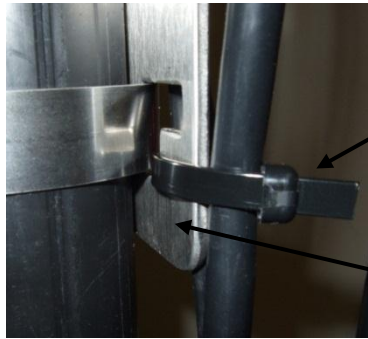

Secure cable using a cable tie and cut off any excess

Secure at widest point for a vertical mount

APPENDIX G Installation Instructions for the IDP-680 CID2 and IDP-690 CID2

Install the IDP-680 CID2 and IDP-690 CID2 (for hazardous environments) following the steps below:

Figure 63 Installation Assembly Diagram

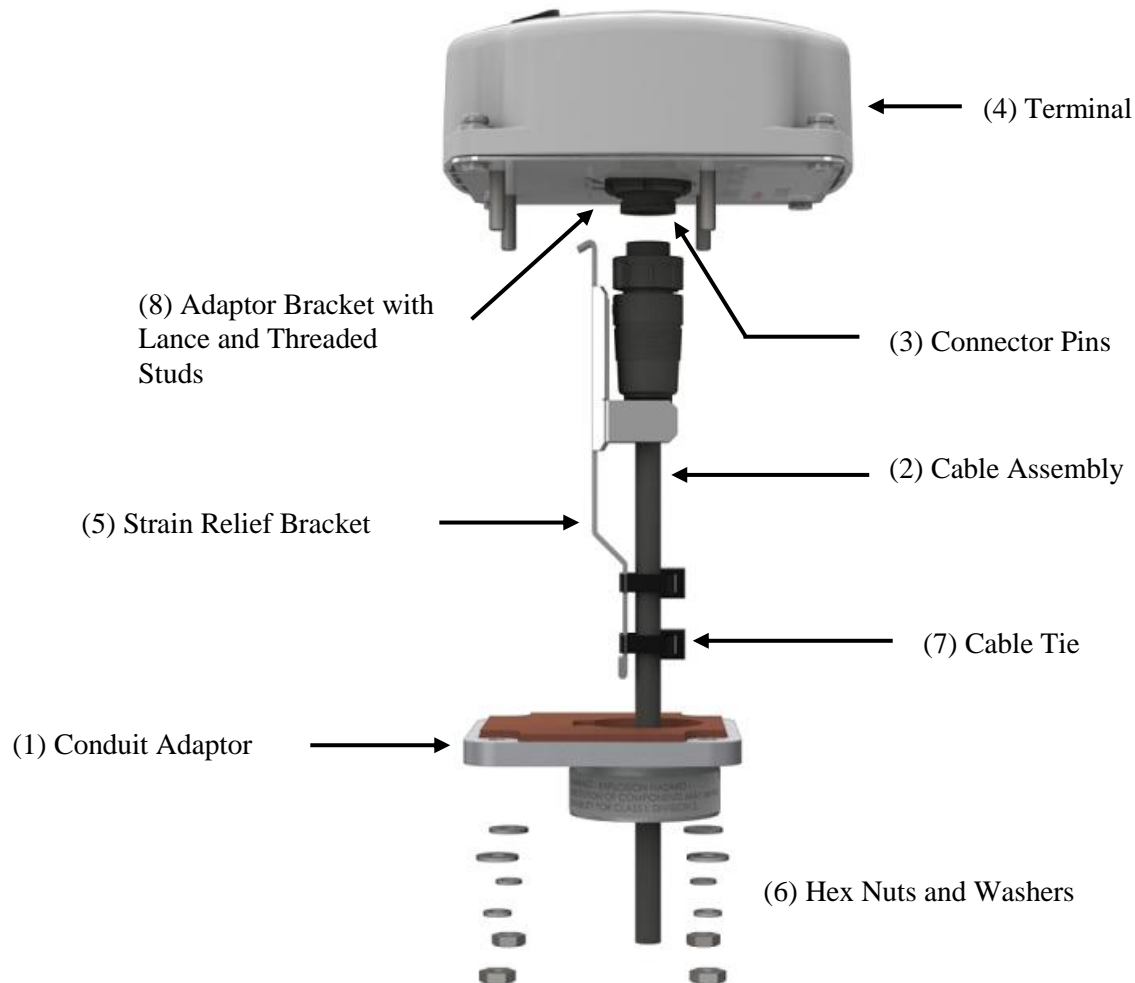

1. Secure the conduit adaptor (#1) to the asset using hazardous location approved 1¼" conduit and fittings. An example of appropriate fitting is shown in Figure 1. Use an outdoor grade flexible adhesive sealant at each connection to maintain a NEMA Type 4 watertight, dust tight protection.

Figure 64 Example Conduit Fitting



2. Pass the cable connector (#2) through the conduit adaptor base.
3. Apply the waterproof silicone lubricant, supplied with the terminal, over the terminal connector pins (#3).

Figure 65 Apply Silicone Lubricant to the Connector

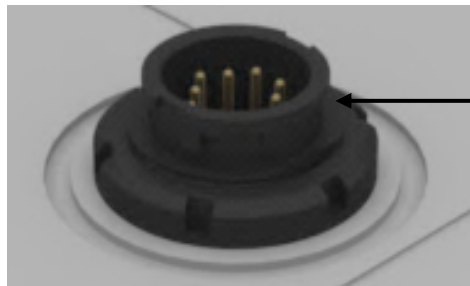

Fill this cavity with silicone lubricant

4. Secure the cable connector (#2) to the terminal (#4) by aligning the mating connector key features and engaging the cable connector locking collar. Remove any excess silicone lubricant.
5. Position the strain relief bracket (#5) in the adaptor bracket lance (#8) next to the terminal connector.
6. Assemble the conduit adaptor (#1) to the threaded studs in the terminal adaptor bracket (#8) using four (4) flat washers, lock washers and hex nuts (#6).
7. Position two cable ties (#7) around the cable at the notches in the strain relief (#5). Do not tighten at this time.
8. Tighten the cable ties (#7) while pulling down on the strain relief bracket (#5). This helps ensure that any stress on the cable does not stress the cable/connector joint.

Note: *To improve performance, point the terminal in the direction of the satellite.*

Note: *A duplicate ISN label is provided in the event that the ISN label on the terminal is obstructed from view once installed. Place the duplicate label in a convenient location.*

APPENDIX H Drill Template

CAUTION Before drilling check the template against actual hardware for dimensional accuracy. If it is not correct, DO NOT USE THIS TEMPLATE.

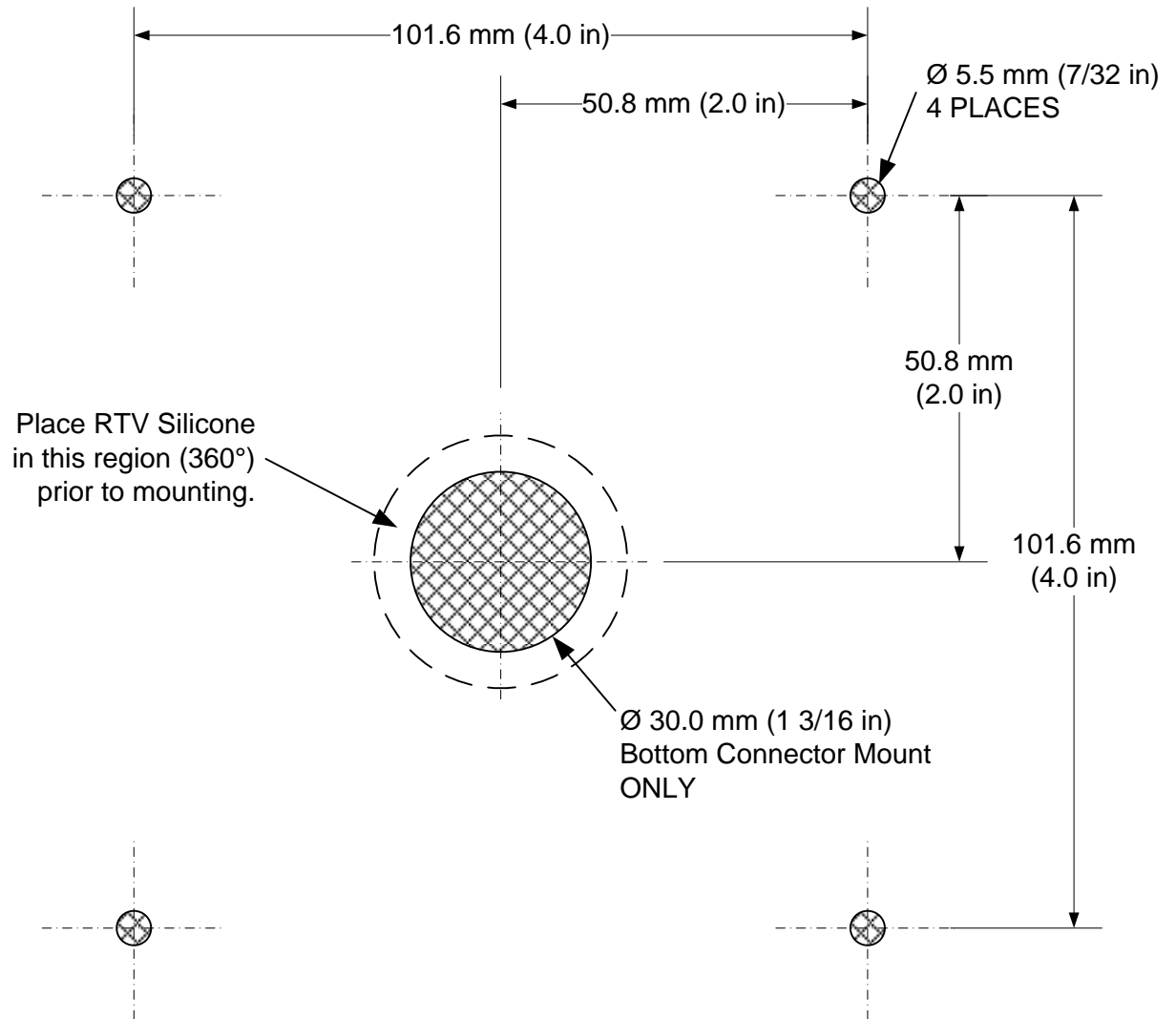

Nominal Dimensions Shown

Documentation Version

Version	Date	Details
05	Jul 2012	See What's New section for details
04	Apr 2012	Added compass safe distance, Added hardware comparison table between existing hardware and new u-blox hardware, Updated certifications, Updated standard GPS information and added new u-blox specifications, Updated order part numbers, Deleted references to J1708 throughout the document.
03	Mar 2012	Updated operating mode descriptions, IDP-690 now IEC 60945 compliant , Added input supply voltage , Added input frequency value for Digital Input , Updated power consumption values, Added average power consumption information , Added absolute limits for open drain and protected open drain Digital Outputs , Updated parameters and values for Analog Input , Updated RS-232 values for Serial Rx Input Low Threshold and Serial Rx Input High Threshold , Updated recommended stripping length figure , Updated order part numbers , New part numbers and details added for IDP 600 Series Mating Cables and Added instructions for the Pole Mount Kit.
02	Nov 2011	Updated elevation angle for IDP-690 (-15 to +90), Added new IDP 600 Series Extension Cable figure and updated details, added power consumption information.
01	Aug 2011	Official customer release
.18	Jul 2011	Limited customer release
.17	Jun 2011	Limited customer release
.13	Apr 2011	Limited customer release
.10	Feb 2011	Limited customer release

Acronyms/Glossary

DC	direct current
ESD	Electrostatic Discharge
FCC	Federal Communications Commission
GND	ground
GPS	Global Positioning System
I/O	input/output
IEC	International Electrotechnical Commission
kgf·cm	kilogram-force centimeter
LED	light-emitting diode
RF	radio frequency
RoHS	Restriction of Hazardous Substances
R&TTE	Radio and Telecommunications Terminal Equipment
Rx	receive
SP	Solution Provider
Tx	transmit

Index...

activation	30, 40	key slot.....	37
Activation Report	31	LED	25, 40
antenna		locking collar	37
elevation angle.....	21	mobile ID	
baud rate	20	format.....	30
compass safe distance.....	9	location	30
connector configurations	3	NVM storage	25
Customer Support.....	ii	operating modes	
elevation angle.....	21, 32	applications processing.....	7
FCC	9	receive.....	6
fuse	15	sleep.....	7
GPS		transmit.....	6
standard	21, 22	part numbers	11, 19, 51
guidelines		R&TTE Directive	10
mounting.....	32	registration	40
IDP terminal		RoHS	10
features	2	RS-232	20
models	3	RS-485	20
IDP-680		safety.....	x
antenna.....	21	serial interface	
dimensions.....	22	RS-232.....	20
figure	3	RS-485.....	20
mass.....	25	settings.....	20
IDP-690		silicone lubricant.....	37
antenna.....	21	software tools.....	1
dimensions.....	23	strain relief.....	34, 38
figure	4	temperature sensor.....	27
Industry Canada.....	9	terminal	
IsatData Pro network		connectors.....	11
description	1	features.....	5
features	1	pin-out.....	12
maximum messages from-mobile.....	1	user serviceable parts.....	xi
maximum messages to-mobile	1	warranty	xi

SkyWave

www.SkyWave.com